

## ELECTRIC FORKLIFT TRUCK OPERATOR'S MANUAL

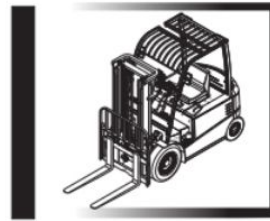

**HELI** 安徽合力股份有限公司  
ANHUI HELI CO., LTD.

# HELI Electric Forklift Operator's Manual

## CPD35 HELI Electric Forklift Truck

For HELI 1-3.5T Electric Forklift CPD10 CPD15  
CPD18 CPD20 CPD25 CPD30 CPD35

### Noted:

1. This operator's manual provides the proper operation, easy maintenance, and routine inspection.
2. Before operation, read this carefully to secure safe and efficient materials handling by proper driving and maintenance.
3. This manual content might not correspond with the actual condition because of the improvement of HELI products.
4. When lend or transfer the forklift truck, this manual should be attached to the forklift truck.
5. If you have any questions, please consult with us for the correct details.



Anhui Leading Forklift Parts Co., Ltd.  
[www.leadingforkliftparts.com](http://www.leadingforkliftparts.com)  
[www.youtube.com/@leadingforkliftparts](https://www.youtube.com/@leadingforkliftparts)

S/11-17-2019

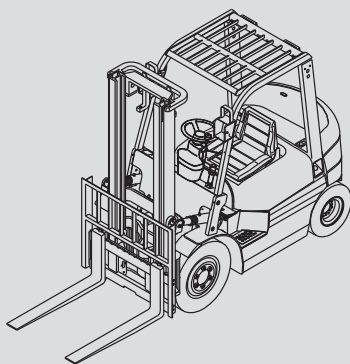

# ELECTRIC FORKLIFT TRUCK OPERATOR'S MANUAL

**HELI** 安徽合力股份有限公司  
ANHUI HELI CO., LTD.

Anhui Leading Forklift Parts Co., Ltd.  
[www.leadingforkliftparts.com](http://www.leadingforkliftparts.com)  
[www.youtube.com/@leadingforkliftparts](http://www.youtube.com/@leadingforkliftparts)

# CONTENTS

I . About Safety .....	1
1.Main Use of Forklift Trucks.....	1
2.Working environment and Areas of Forklift Trucks .....	1
3.Safety Problem Before Use.....	3
4.Safety Problem During Operation.....	7
5.Safety Problem During Service.....	17
6.Safety Problem of Battery Using.....	19
7.Decal .....	22
II . Operation Device & Use Method .....	31
1.Liquid Crystal Displayer .....	34
2.Switches.....	37
3.Controls .....	38
4.Body and Others .....	41
III. Driving and Operation .....	48
1.During Break-in.....	48
2.Relationship Between Load and Stability of Truck .....	48
3.Load Center and Rated Load .....	49
4.Stability of Forklift Truck .....	49
5.Transporting and Loading the Truck .....	49
6.Preparation for Start .....	50
7.Driving .....	52
8.Battery's Using Method .....	54
9.Stacking Operation .....	60
10.Picking Operation.....	61
11.Storing .....	62
12.Washing the Truck .....	64
13.How to Move a Disabled Lift Truck .....	65
IV . Periodic Inspection & Servicing .....	66
1.Inspection Prior to Operation .....	66
2.Inspection of After Operation.....	73
3.Weekly(50-hour)Servicing .....	73
4.Monthly(200-hour)Servicing .....	75
5.Every Three-month(600-hour)Servicing .....	76
6.Semiannually(1200-hour)Servicing .....	76
V . Others .....	79
1.Lubrication Points and Recommended Oil .....	79
2.Replacing Parts Guidance.....	81

# INTRODUCTION

This manual should be kept by operator and read it repeatedly.



- This operators manual provides the proper operation, easy maintenance and routine inspection.





- Prior to operation, read this carefully to secure safe and efficient materials handling by proper driving and maintenance.

- This manual content might not correspond with the actual condition because of the improving of our products.

- When lend or transfer the forklift truck, this manual should be attached to the forklift truck.

- If you have any questions, please consult with the sale apartment of our company.

 and  marked instruction is very important to you and others for safety. You shall keep to the instruction.

 DANGER	Indicates an imminently hazardous situation which, if not avoided, will result in death or serious injury. You must observe this instruction.
 WARNING	Indicates a potentially hazardous situation which, if not avoided, could result in death or serious injury. You must observe this instruction.
 CAUTION	Indicates a potentially hazardous situation which, if not avoided, may result in minor or moderate injury. You must observe this instruction.
 NOTE	Indicates a statement of directly or indirectly related to the safety of personnel and maintain of the truck.

## I . ABOUT SAFETY

Safety is your business and your responsibility. The “ABOUT SAFETY” covers basic safety procedures and warnings of general application to the typical forklift truck. However, safety precautions given on the following pages are also applicable to lift trucks that have special specifications or attachments.

### 1.Main Use of Forklift Trucks

#### (1)Main use of forklift trucks

The main use of forklift trucks is handle and stack the loads that on the pallets. When they are assembled with proper attachments, they also can handle and stack the loads that not on the pallets.

#### (2)Prohibitive use

The following prohibitive uses are not allow to use anyway.

- Stand on the forks or pallets and rise
- Stand on the pallets to press the loads.
- Hoist the loads with the steel wire rope hang on the forks directly.
- Tow other trucks.
- Push the loads or other trucks with forks.
- Open or close the doors of other trucks with forks.

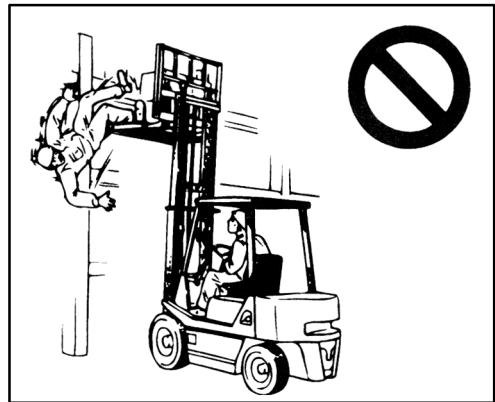
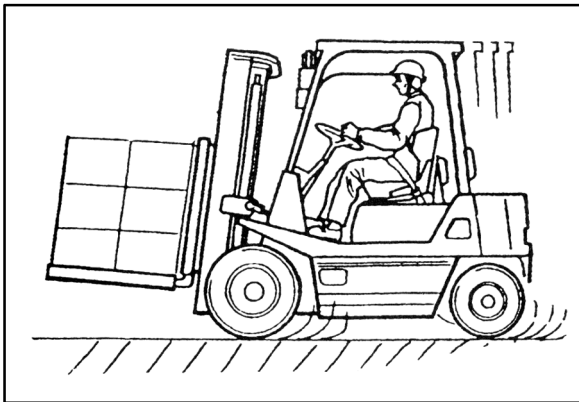

### 2.Working Environment and Areas of Forklift Trucks

#### (1)Ground condition

Keep good condition of flat road surface and ventilation.

Lift truck performance depends on the ground or floor conditions and travel speed should be adjusted properly. Use extreme care when operating on a ramp or rough ground or floor.

**⚠ WARNING**

·When crossing the railroad, be sure to once stop and make sure to be safe.

·Go around rocks and stumps. If unavoided, reduce speed and go slowly and carefully. Use caution not to damage the bottom of the truck.

When traveling on grounds covered with snow or ice, use tire chains. On such ground conditions, avoid sudden accelerations, stops, or turns. It is good practice to control the travel speed by accelerator pedal effort.

**⚠ WARNING**

·When equipped with tire chains, the truck get a larger driving power. However, sideway antislip performance is almost reduced so extreme care should be used.

(2)Weather condition

Do not operate the truck outside when it's raining.

**⚠ CAUTION**

·Do not rise the mast too high in the air when it's windy, this will lead to a dangerous condition unexpectedly.

·The time scale between the indoor work and outdoor work of the truck for cold storage should be the same. The indoor working time should be no more than 30 minutes. Never keep the truck in the cold storage.

·Try to avoid work outdoor on rainy days.

(3)Measures against cold and hot weathers

a)Oil

Use the oil suitable for ambient temperature.

b)Battery

·Lead-acid battery

In cold weather

Under normal charged conditions, the freezing point of electrolyte is about -35°C.

Always keep the battery in a well-charged condition since there is danger of damaging the battery jar if electrolyte freezes. To prevent the freezing, charge at least 75% of the whole capacity.

Also it is effective to keep the specified gravity up to 1.260, but not higher than this value.

In hot weather

As the water of electrolyte is especially likely to evaporate in hot weather, replenish distilled water from time to time. Check the battery once a week, and supply distilled water.

In a region where the ambient temperature is intensely hot, it is practicable to lower the specified gravity of a completely charged battery down to 1.220±0.01.

Since the battery is better in efficiency under hot temperatures, no other cares are needed.

## **⚠ DANGER**

·Gases produced by the battery can be explosive. Do not smoke, use an open flame, create an arc or sparks in the vicinity of the battery. Ventilate well when in an enclosed space and when charging. The battery contains **SULFURIC ACID** which causes severe burns. Do not get in eyes, on skin or clothing. In case of contact, flush immediately and thoroughly with clean water. Obtain medical attention when eyes are affected.

### c)Radiator coolant

Your lift truck is generally shipped with the cooling system filled with Long Life Coolant (LLC)of 50% volumetric mixture. The freezing point of the coolant of such a mixing ratio is -35°C.

In hot weather, to maintain good cooling effect, special care should be paid to radiator and cooling system. Parking in the shade is recommended.

### ·Lithium battery

#### Charging temperature requirements

Charging temperature range:0-40°C, big multiplying power charging under 0°C will harm the battery. Charge the battery at once after using the truck under 0°C.

#### Battery discharging requirements

Battery discharging temperature stays between -25°C and 50°C. The battery discharging capacity will be badly affected in low temperature (-25°C-0°C) compared with ambient temperature condition. This is normal. The battery can be used between 40-50°C, but if the environment temperature is high, especially when the battery works under such high temperature for a long time, it will increased the aging of battery interior material and shorten battery life. So it is not recommended to work under such temperature for a long time.

The most effective handling measure is that do not operate the truck when the environment temperature exceeds 55° or lower than -25°C..

**DANGER:** Do not smoke or use open fire. Make sure there is no arc and spark near the lithium battery. when the battery is charged or stored in closed space, make sure it is well ventilated.

(4) Do not use the truck in explosive environment

### **3.Safety Problem Before Use**

(1)Get permission from supervisor

**⚠ CAUTION**

- Only trained and authorized operator shall be permitted to operate the truck.
- The characteristic of brake, accelerator and hydraulic control levers are different an every truck which has same specification. After getting accustomed to operating, operate the forklift truck.

(2)Clothing of forklift truck working

**⚠ CAUTION**

- Wear a helmet, safety shoes and a working clothes.
- For security, do not wear a loose clothes which has a fear to be hooked or caught in. When hooked the clothes, this will lead to a dangerous condition unexpectedly.

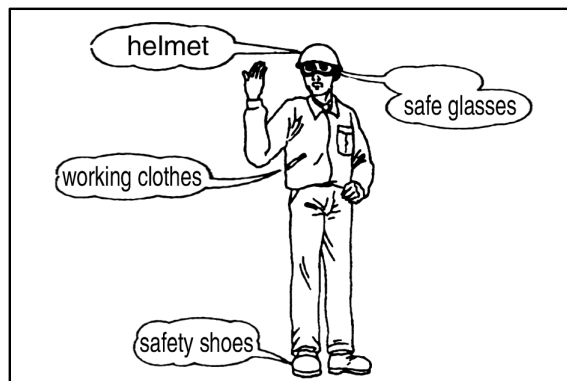

(3)Do not operate after drinking

**⚠ CAUTION**

- Do not operate the forklift truck when you have tired, mix emotional problems, drugs or alcohol.



(4)Safety for your place of work

**⚠ CAUTION**

- Keep good condition of road surface, traffic control should be clear.
- Lighting for operating area is needed for safety working.
- Operating on a platform and dockboards is in danger of turnover, provide wheel stops or other positive protection to prevent a turnover.

(5)Keep clean condition of operator's compartment

**⚠ CAUTION**

- Operator's compartment shall be kept in a clean condition at all times.
- When having slippery oily hands or muddy hands, this condition will lead a dangerous operation.
- Tools and other metallic objects shall be kept away from the operator's compartment. These obstruct the movements of lever or pedal.

(6)Truck complete

Only in the event that the truck manufacturer is no longer in business and there is no successor in the interest to the business, the user may arrange for a modification or alteration to a powered industrial truck, provided, however, that the user shall:

- Arrange for the modification or alteration to be designed, tested and implemented by an engineer(s) expert in industrial trucks and their safety;
- Maintain a permanent record of the design, test(s) and implementation of the modification or alteration;
- Approve and make appropriate changes to the capacity plate(s), decals, tags and instruction handbook;
- Affix a permanent and readily visible label to the truck stating the manner in which the truck has been modified or altered together with the date of the modification or alteration, and the name and address of the organisation that accomplished the tasks.

**⚠ CAUTION**

- Truck should be equipped with an overhead guard and a load backrest.

**👉 NOTE**

·An overhead guard shall be used as protection against falling objects. It should be noted that an overhead guard is intend to offer protection from the impact of small packages, boxes, etc., representative of job application, but not to withstand the impact of falling capacity load. Precaution shall be taken to falling objects.

**⚠ WARNING**

·Modifications and additions shall not be performed without the written approval of our company.Modifications might affect capacity or safety operation.

·Do not install any parts blocking visibility from operating position.

(7)Periodic servicing

**⚠ CAUTION**

·Carry out daily servicing and periodic servicing.

**⚠ WARNING**

·When find a damage or a fault at the truck, stop operating the truck and inform an employee about the truck condition immediately. Do not operate the truck until the truck has been repaired completely.

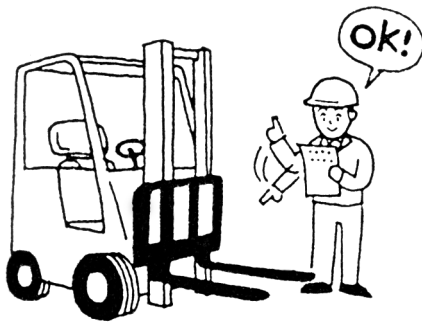

(8)Avoid fire hazard

**⚠ CAUTION**

·Setting fire extinguisher to avoid fire hazard, accident or other indeterminism thing. Use the fire extinguisher according to it's operating rules.

(9)Prohibition of overload

**⚠ CAUTION**

·Do not overload and observe the allowable load and the capacity chart on the truck. Make sure the weight of load and the center of gravity at the load position.

**👉 NOTE**

·Allowable capacity means what the maximum load can be put on the forks in accordance with a load center.



(10) Using a proper pallet

**⚠ CAUTION**

- Use a pallet which is suitable size and strength for a load.
- Make sure palletised load is in proper shape and securely palletised.
- Prohibition of handling materials without pallets.



(11) Before using the lift truck, make the following checks:

- Oil level in the hydraulic tank.
- Electrolyte level and specific gravity of the battery are correct.
- Battery weight is within the range of battery weights on the nameplate.
- Battery restraint mechanism

operates correctly and is latched.

· Condition of forks, carriage, chains, mast and overhead guard.

· Leaks from the hydraulic system.

· Condition of wheels and tires.

· Seat belt fastens correctly.

· Seat is securely fastened to the seat plate or hood.

· Check if the truck charging opening cover is closed.

#### **4. Safety Problem During Operation**

(1) Cautionary proceeding for start

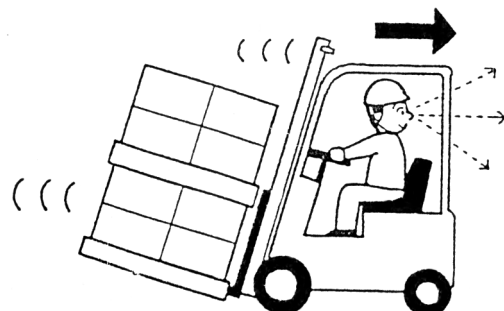

**⚠ CAUTION**

- The parking brake lever is applied securely.
- The directional switch lever is in “N”.
- Depress the clutch pedal or the brake pedal.
- Adjust the seat so you can get easy access to all hand and foot controls.
- Make sure no one is under, on and close to the truck.

(2) Safety around the truck

**⚠ CAUTION**

·When carrying the large load and visibility is poor, make a drive backward or someone should induces the truck.

·When driving backward, make sure no person is around the truck. The rear view mirror and the buzzer are for helping. If rear handle for horn button is installed on the truck, it is also auxiliary device.

·Someone should induces the truck at narrow aisle.

·The driver shall be required to stop at cross aisles and other location where vision is obstructed and make sure security at right and left of the truck.

·Make sure the safety distance from sideways or platform's edges. Working on the sideways or platform may cause the truck dropping, put stopper and so on.

·A forklift truck is a rear wheel steering which is different from a car, slow down the traveling speed and approach to a turing corner then operate steering wheel with taking care of a turn at the truck back.

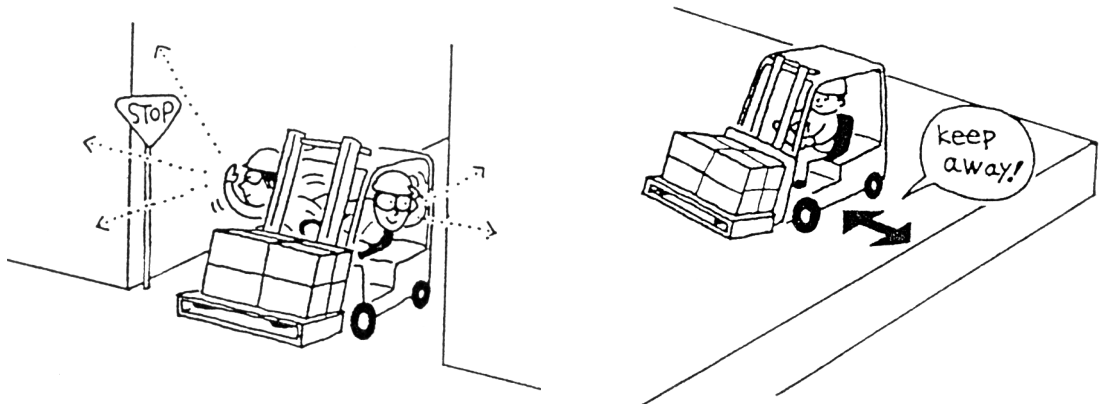

(3) Prohibition of rough driving

**⚠ CAUTION**

- Do not turn on the key switch with depressing the accelerator pedal.

·Do not make a sudden start, braking or turn. A sudden start and braking can cause a falling of load. A sharp turn on traveling can cause a overturn of truck and may relate to a serious accident.

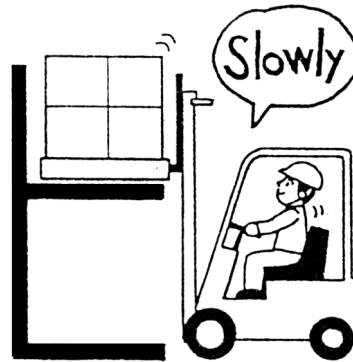

·Operate hydraulic control levers slowly when loading and unloading. There is a danger of falling load or overturning the truck when operating the levers suddenly at high height position of forks.

 NOTE

- Do not run over bumps and obstacles scattered on the road.
- When passing by the other truck, slow down the traveling speed and sound the horn.
- Do not drive into a weak floor or ground.
- Slow down the traveling speed on a wet, slippery, uneven and inclined place, etc.
- Make sure that there is sufficient clearance between mast and ceiling or entrance of a structure.

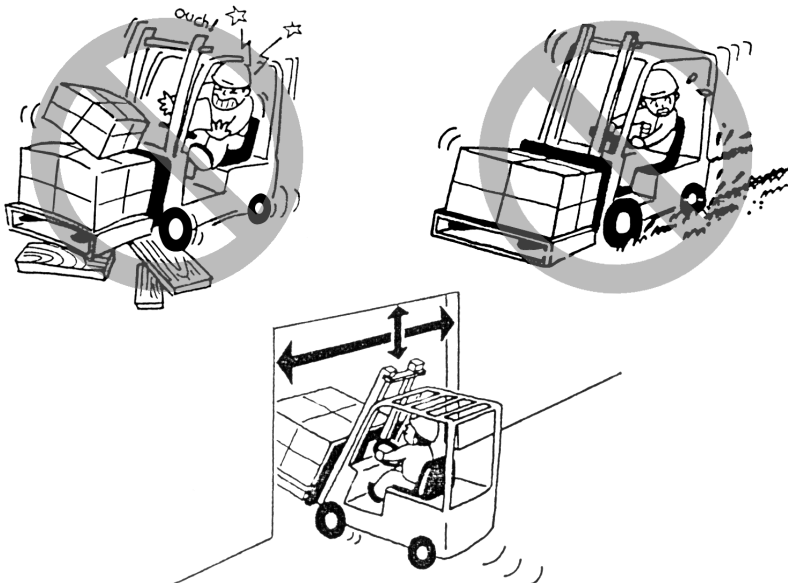

(4) Prohibition of driving with forks lifted up in the air

**⚠ CAUTION**

· Do not drive with forks lifted up. When traveling with lifted forks, this could cause an unstable condition and a turn over of the truck.

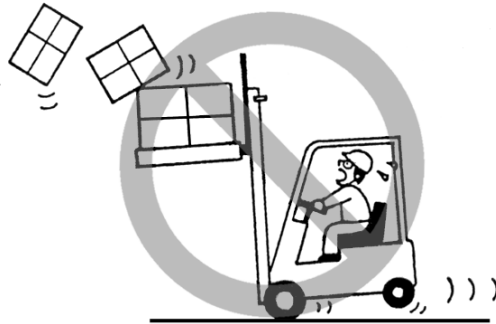

(5) Prohibition of fork tip working

**⚠ CAUTION**

· Do not push a load or lift up by the tip of forks. When catch a load by the tip of forks, it can cause jumping the truck or a load.

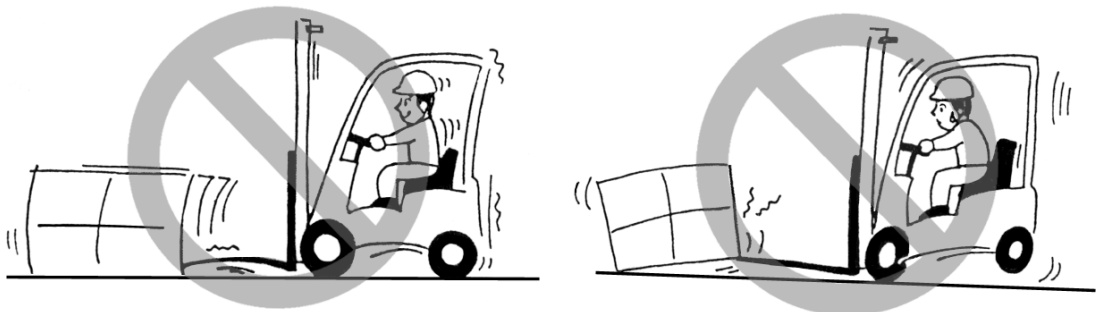

(6) Prohibition of pushing and pulling working

**⚠ CAUTION**

· Do not push or pull a load. The load would be damaged or dropped.

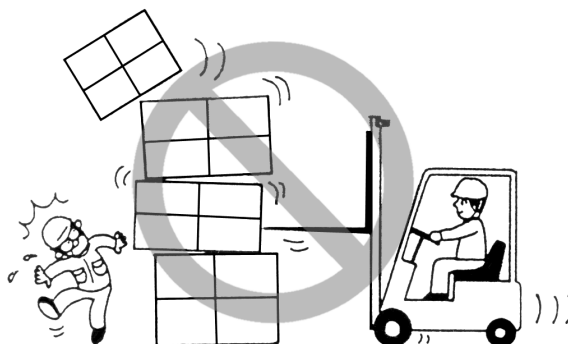

(7)Driving on a slope

**⚠ CAUTION**

·Drive the truck on a slope as following.

**LOADED:**Drive the truck forward to ascend and backward to descend.

**UNLOADED:**Drive the truck backward to ascend and forward to descend.

·When the truck goes down on a slope, drive slowly with the brakes on. Make sure that the forks should not touch the ground.

·Driving, turning and loading shall not be taken on a slope. It could cause turning sideways of the truck, it is very dangerous.

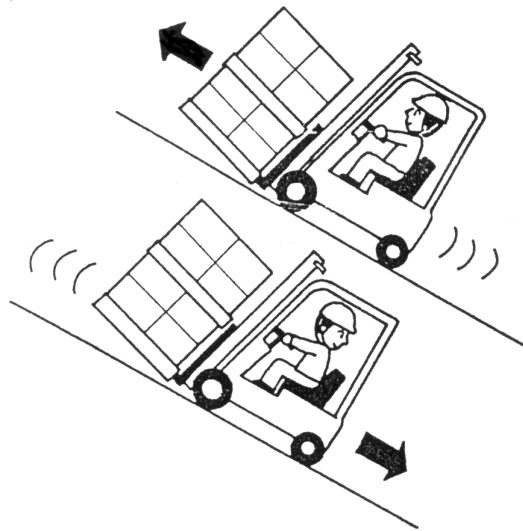

(8)Prohibition of off-center loads

**⚠ CAUTION**

·Make sure if loads are arranged stable and safely, insert the forks to the pallet correctly and care must be taken not to handle off-center loads.

·To handle off-center loads could lead to overturn the truck and falling loads.

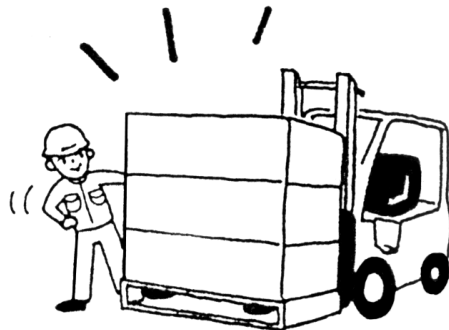

(9) Prohibition of permitting passengers to ride

**⚠ WARNING**

- Do not permit passenger to ride on the forks or a pallet.
- Do not ride people on the truck except driver.
- Do not ride people on the truck as a counterbalance.
- Do not stand on the load or pass under forks.



(10) Prohibition of putting into mast structure

**⚠ WARNING**

· Never put any part of the body into the mast structure or between the mast and truck.

**⚠ CAUTION**

· Keep hands and feet inside the operator's compartment. Do not put any part of the body outside the operator compartment of the truck.

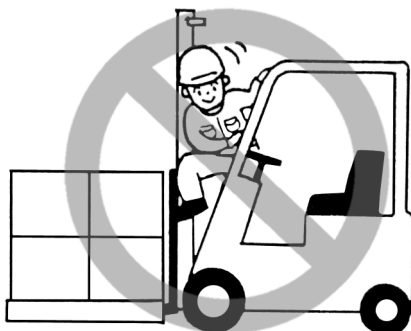

(11) Prohibition of lifting when tilting loads forward

**⚠ CAUTION**

· Do not lift up load and drive a truck when tilting the mast forward. When lifting loads or diving the truck, tilt the mast backward enough and stabilize the load. When traveling with or without load, raise the forks for 150-200mm from the floor.

- Do not tilt the mast forward with the load.
- When lifting or lowering the load, be sure to stop the truck.
- Do not load and unload the load at the condition which the truck is leaning.

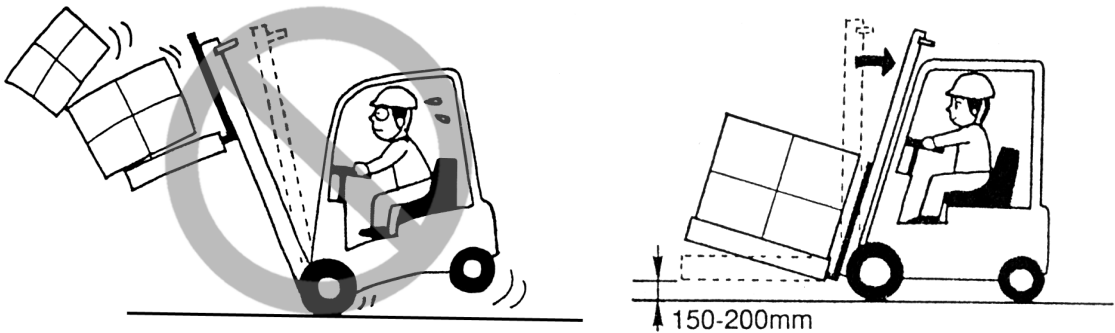

(12) Driving into trailer

**⚠ CAUTION**

· Operate the truck at the place where has holding means of a trailer at docks.  
· Before starting operation of truck, fix a dockboard and inspect it's strength.  
· When getting into or off the trailer, drive carefully and slowly across the dockboard or bidge plate.

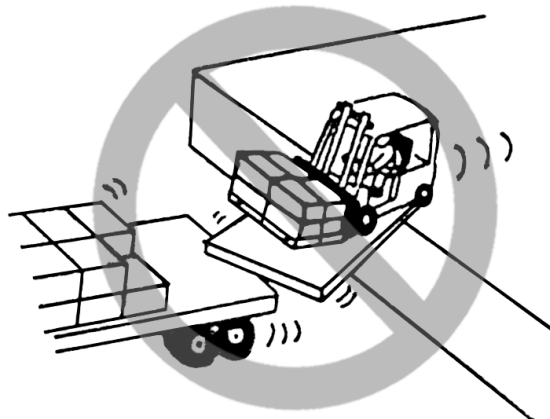

(13) Getting on and off truck

**⚠ CAUTION**

- Do not jump on and off the truck.
- When get on and off the truck, grasp a grip, put on your foot at step and supporting your body.
- When getting on the truck, do not grasp a steering wheel or hydraulic control levers.

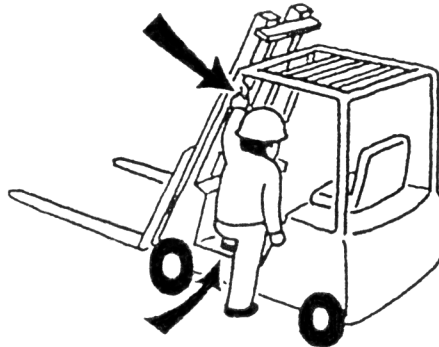

(14) Prohibition of loading high stacked loads

**⚠ CAUTION**

· Loaded load should be contacting with a load backrest. Do not handle the load which a exceeded height of a backrest. When loads go over a load backrest, there is a danger of loads's falling against operator.

· When making a double stack loading, fasten the loads with rope to protect falling of loads.

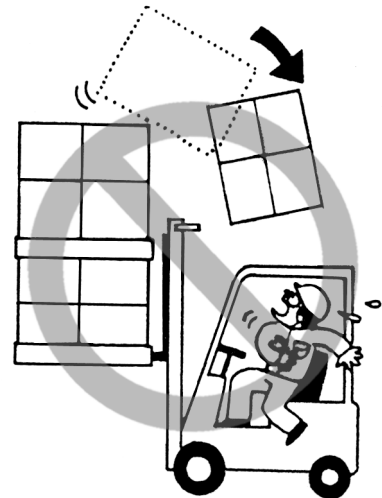

(15) Loosen chains

**⚠ CAUTION**

· Do not draw out the forks from a pallet when chains are loosen. When chains are loosen, there is a danger of catching loads and rack by forks or falling of loads and overturning of truck.

**👉 NOTE**

· When chains are loosen, pull the lift lever a little and lift the forks, the loosen chains could be corrected. After correcting the loosen chains, draw out the forks from a pallet.

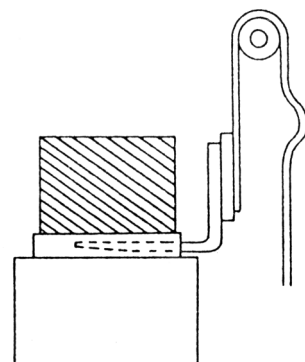

(16) Adjustment of forks

**⚠ CAUTION**

·Adjust the spreading of forks in accordance with a pallet size. Care must be taken not to pinch fingers when adjusting a spreading of forks.

·When adjusting the width of forks, make sure that the setting pin of forks are fixed. When the forks are not fixed, the forks could move and there is a danger of load's crumbling and falling.

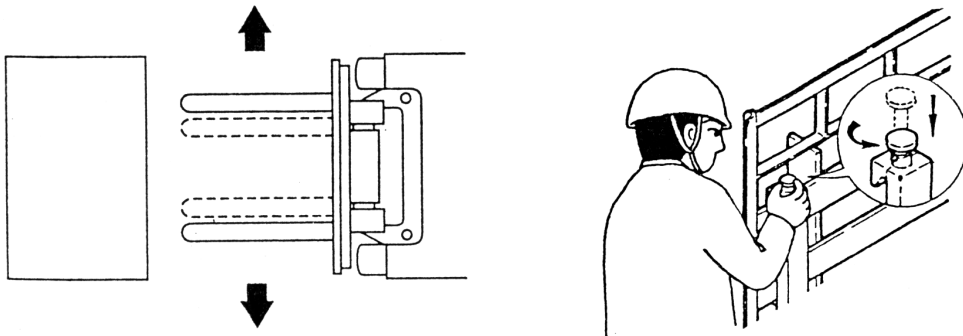

(17) Handling of wide loads

**⚠ CAUTION**

- Careful driving should be taken when handling long or wide loads.
- Be careful of around security when turning, and turn slowly in order not to move loads.
- Be careful of balancing of loads, and handle the loads at low height position.
- Lifting and lowering loads should be slowly, and be careful of around security.

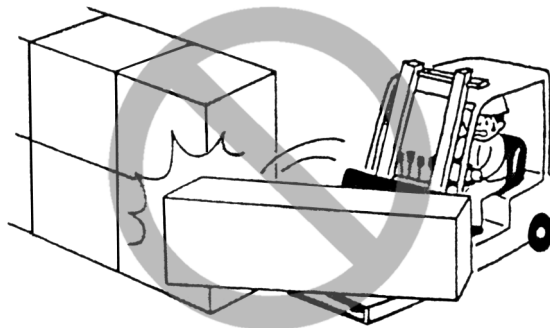

(18) Prohibition of holding down loads by hands

**⚠ CAUTION**

· Do not hold down the loads by hands. There is a danger of load's falling.

(19) Parking of disabled forklift truck

**👉 NOTE**

· When park the off road forklift truck, warning or "out of order" signs shall be placed on the truck and remove the key.

· When the forks could not be lowered by fault, place a large mark in order not to be hit by other truck or walkers.

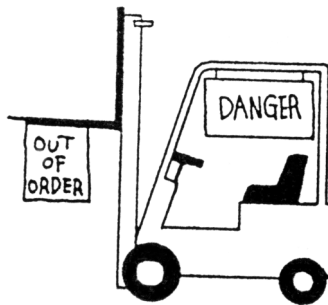

(20) Information of after finished working

**👉 NOTE**

Before leaving the truck:

· Tilt the mast ass'y forward and fully lower the forks. If do not lower the forks to the floor, there is a danger of stumbling or hitting body.

· Place direction lever or rocker switch on neutral position.

· Apply the parking brake or press the hand brake button or switch.

· Turn off the key switch and remove the key.

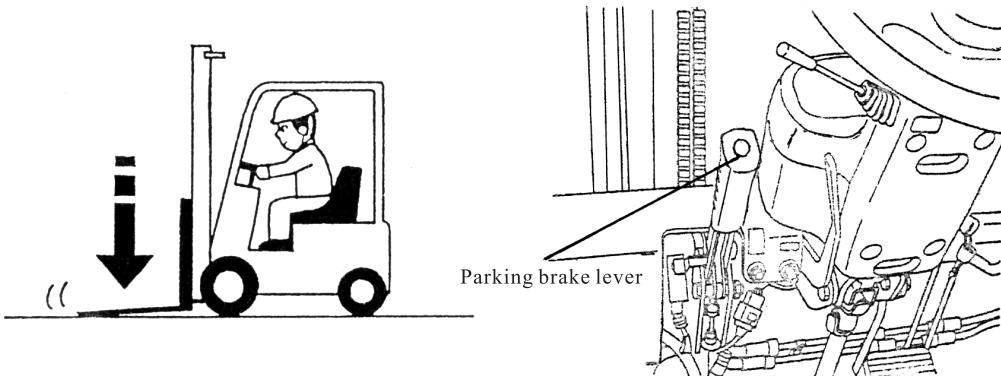

(21)Parking

**⚠ CAUTION**

- Park at reserved place.
- Parking place should be hard sufficiently and does not disturb a traffic.
- Do not park on or near an inflammable object.
- Do not park trucks on a slope. When park trucks on a slope, the trucks could move inconceivable. When park trucks on a slop by necessity, put wheel drags securely.
- For lithium battery powered truck, if the parking time will be longer than 72h, please press the emergency button.

(22)Noise

According to the measure method specified in EN12053, max.noise at the outboard of the truck is 90dB(A).It is measured in sound pressure level at the operator's position and in sound power level around.

**⚠ CAUTION**

- Driving on the rough road will make the noise of the truck be increased as well as the distortion of the tyres.

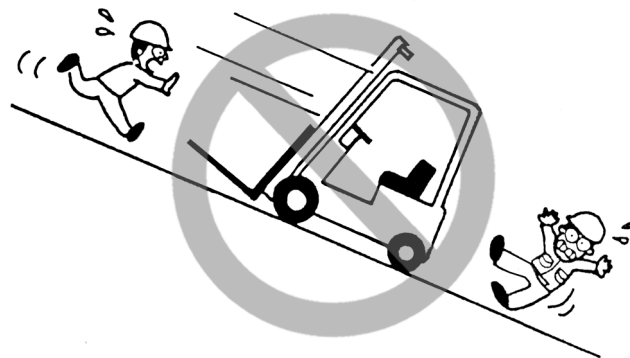

## 5.Safety Problem During Service

(1)Service place

**⚠ CAUTION**

- Servicing facility should be provided adequate equipment and safety guards, and this place should be appointed.
- Servicing place should be a flat footing.
- Servicing place should be provided for adequate ventilation.

·Fire extinguishers shall be provided at the servicing facility.

(2)Precautions of service

**⚠ CAUTION**

·Smoking shall be prohibited.

·Wear safeguard (helmet, shoes, glasses, gloves and boots) and suitable clothes.

·Wipe off split oil at once.

·On lubricating, lubricate after removing grease and dust off nipples and fittings with a brush or a cloth.

·Turn off key switch and pull out the battery plug except being in case of need.

·When servicing a forklift truck, lower forks to the floor.

·Clean the electrical components with compressed air.

(3)Cautions of service

**⚠ CAUTION**

·Care must be taken not to put your feet under forks and not to stumble over forks.

·When forks are lifted up, put blocks under an inner mast not to fall down forks and mast.

·Care must be taken not to snip your hands when opening and shutting of a floor plate and a battery cover.

·When having a group work, proceed working by making a sign each other.

·Use suitable tools and do not use temporary tools.

·As maintenance of hydraulic circuit is always high pressure condition, do not work before lowering inside pressure.

·When being struck by a high voltage shock, consult a physician immediately.

·Do not use a mast ass'y instead of a ladder.

·Prohibit putting into your hands, feet and body between the frame and mast ass'y positively.

·Bear in mind that the transmission or the hydraulic system can be hot while operating. Let the truck cool before servicing to avoid burning.

(4)Inspection and exchange of tyre

**⚠ CAUTION**

·Leave a dismantling and mounting tyres to qualified service facility by our company.

·Handling a high pressure air shall be made by authorized personnel.

·When use a compressed air , wear goggle.

·When dismantling the tyre, do not loosen bolts and nuts of joint rim. As inside tyre is high pressure, there is a danger of breaking bolts, nuts and rim.

(5) Jack up working (exchanging tyres)

**⚠ WARNING**

·Do not enter under the truck while jacking up the truck.

**⚠ CAUTION**

·Before jacking up, make sure that nobody in the truck and no load on the truck.

·When wheels rise up from ground, stop jacking up and put blocks under the truck to prevent the truck falling down.

·Before jacking up, put wheel drags.

(6) Drain the waster (electrolyte, oil, etc.)

**⚠ CAUTION**

·The waster of the forklift truck must be reclaimed obeying the government's rules. Do not drain the waster randomly.

## 6. Safety Problem of Battery Using

### 6.1 Safety problem of lead-acid battery using

(1) Smoking shall be prohibited

**⚠ CAUTION**

·A battery produces hydrogen gas. When making a short circuit, sparking and a fire of cigar approaching to the battery, it causes an explosion and a fire.



(2) Prevention of an electric shock

**⚠ CAUTION**

·The battery has a high voltage. Do not touch the electric conductor of the battery when installing and servicing. It causes a serious burn.

(3) Connecting correctly

**⚠ CAUTION**

·Do not charge the battery which the terminal is changed places with the

**terminal. It cause heating, ignition, smoking and an ignite explosion.**

(4)Prohibition of putting a kind of metallic goods on the battery surface

**⚠ CAUTION**

·Do not make a short circuit between both terminals by bolt or tool. It causes injuries and an ignite explosion.

(5)Prohibition of over discharging

**⚠ CAUTION**

·Do not operate the truck until it does not move. The battery life will be shortened. When the battery capacity warner flushes, charge the battery.

(6)Keep clean

**⚠ CAUTION**

·Keep the upper surface of the battery clean.

·Do not use a dry cloth, a chemical fiber cloth for cleaning the battery surface.

**And do not cover the battery by a vinyl sheet.**

·It causes a ignite explosion by a static electricity.

·Use a wet cloth for cleaning the top of uncovered battery.

(7)Wearing safeguard

**⚠ CAUTION**

·When servicing the battery, wear goggle, rubber gloves and boots.



(8)Electrolyte of battery is hazardous

**⚠ CAUTION**

·The electrolyte of battery is made of the dilute sulphuric acid. Handling should be taken care.

·When the electrolyte adheres to eye, skin and clothes, it causes to lose eyesight

and a scald.

(9)Emergency first aid



When an accident is occurred, take the emergency first aid as following and consult a physician immediately.

- Spilled on the skin: It should be washed off with water for 10-15 minutes.
- Splashed in eye: It should be washed off with water for 10-15 minutes.
- Flow out on a large scale: Neutralize the electrolyte of battery by the baking soda (sodium bicarbonate) or it should washed off with water.
- Swallowed: Drink milk or water on a large quantity.
- Splashed on clothes: Take off clothes immediately.

(10)Close the vent caps securely



·Close the vent caps of the battery securely in order not to leak the electrolyte of battery.

·Care must be taken not to refill electrolyte excessively. An overflowed battery could cause a electric leakage.

(11)Washing



·Do not wash the truck which the battery is getting on. If washing the battery, it causes damage to the truck.

·Tighten the vent caps in order to protect water.

(12)Sea water



·The battery should not be got wet with rain or sea water. It causes a damage of battery or fire.

(13)Abnormal battery



When the battery shows the following condition, contact sale apartment of our company.

- The battery stinks.
- The electrolyte becomes muddy.
- The temperature of electrolyte is high.
- The decreasing speed of electrolyte is fast.

(14)Prohibition of disassembling

### **⚠ CAUTION**

- Do not drain the electrolyte from the battery.
- Do not disassemble the battery.
- Do not repair the battery.

(15)Storage

### **⚠ CAUTION**

·When do not use the battery for a long time, store it in the place where is well ventilated and there is no sign of fire.

·When the truck will not be used for a long time, charge the battery to make its quantity to 40~60%. Do not be full. Disconnect the battery and truck. if the battery is connected with forklift truck, the emergency button must be pressed.

(16)Abandonment of battery

### **⚠ CAUTION**

·Regarding used batteries, please contact relative professional companies or handle according to local regulations. It is prohibited to abandon at will which will result environment pollution.

6.2 Safety problem of lithium battery using

(1) Notes during operation

·Do not operate the truck when the temperature is higher than 55℃ or lower than -25℃.

(2) Charging in low temperature

·Charge the battery at once after using the truck under 0℃.

(3) Cleaning

·It is prohibited to wash lithium battery with water or battery will be damaged.

**Prevent the battery from getting water.**

(4) Maintenance

·For better using effect, please contact manufacturer every half a year to do battery performance check and equalizing charging.

(5) Transporting

·During transporting, make sure the truck is disconnected with charging equipments, the battery quantity stays between 40% and 60% and the emergency button is pressed.

## **7.Decal**

The decals sticking on the trucks are used to explain to the driver how to operate the truck and what to pay attention to. When any of them fall off the truck, please re-stick it at

once.

(1) Decal of safety

**⚠ WARNING**





(2) Decal of notice

**⚠ CAUTION**

<b>GENERAL INFORMATION WHEN OPERATING</b>									
<b>Start</b>	<p>Persons who have not been properly trained must not operate this forklift truck.</p> <p>Check all controls and functions before operation. Do not operate if malfunctioning.</p> <p>Drive and operate the truck smoothly at all times.</p> <p>Driver should apply handbrake, switch off power and alight from truck during battery charging.</p>								
<b>Operate</b>	<table border="0"> <tr> <td style="text-align: center;">     <p>Do not carry unsecured loads</p> </td> <td style="text-align: center;">     <p>Overloading is prohibited.</p> </td> <td style="text-align: center;"> <p>Take care not to unbalance loads at high levels</p> </td> <td style="text-align: center;"> <p>Forks must be fully under load</p> </td> </tr> <tr> <td style="text-align: center;">     <p>Only operate the truck when sitting in the seat</p> </td> <td style="text-align: center;">     <p>Never lift loads on a single fork.</p> </td> <td style="text-align: center;"> <p>Beware low heights</p> </td> <td style="text-align: center;"> <p>Use minimum tilt at high levels</p> </td> </tr> </table>	  <p>Do not carry unsecured loads</p>	  <p>Overloading is prohibited.</p>	<p>Take care not to unbalance loads at high levels</p>	<p>Forks must be fully under load</p>	  <p>Only operate the truck when sitting in the seat</p>	  <p>Never lift loads on a single fork.</p>	<p>Beware low heights</p>	<p>Use minimum tilt at high levels</p>
  <p>Do not carry unsecured loads</p>	  <p>Overloading is prohibited.</p>	<p>Take care not to unbalance loads at high levels</p>	<p>Forks must be fully under load</p>						
  <p>Only operate the truck when sitting in the seat</p>	  <p>Never lift loads on a single fork.</p>	<p>Beware low heights</p>	<p>Use minimum tilt at high levels</p>						
<b>Travel</b>	<ul style="list-style-type: none"> <li> Slow down when driving in the wet.</li> <li> Beware when driving on slopes. When slope is greater than 10% drive forwards up the slope and drive backwards down the slope.</li> <li> Electric Forklift Truck: While driving and climbing, the current brake will be lost if the emergency switch was shut off.</li> <li> Take caution when driving on uneven surfaces.</li> <li> Never carry people on the forks.</li> <li> Do not turn on slopes.</li> <li> Always lower load and tilt back when travelling.</li> </ul>								
<b>Stop</b>	<p>When parking truck lower forks to the ground, tilt the mast upright apply the handbrake and switch off the power. Never park on a slope.</p>								

(3)Name plate

ELECTRIC COUNTERBALANCED FORKLIFT TRUCK		<b>HELI</b>	
Model	<input type="text"/>	Configuration No.	<input type="text"/>
Rated Capacity	<input type="text"/>	Total Weight	<input type="text"/>
Rated Voltage/ Capacity(5h)	<input type="text"/>	Total Weight (without battery)	<input type="text"/>
Rated Power	<input type="text"/>	Battery Weight (Max)	<input type="text"/>
Serial No.	<input type="text"/>	Battery Weight (Min)	<input type="text"/>
No. of Manufacture License	TS2510341-2020	The Year of Construction	<input type="text"/>

**Compliance With ISO 3691**  
 Add: 163 Woyun Road, Hefei,  
 Anhui, P.R. China  
**ANHUI HELI CO., LTD.**

(4)Decal of lubrication chart



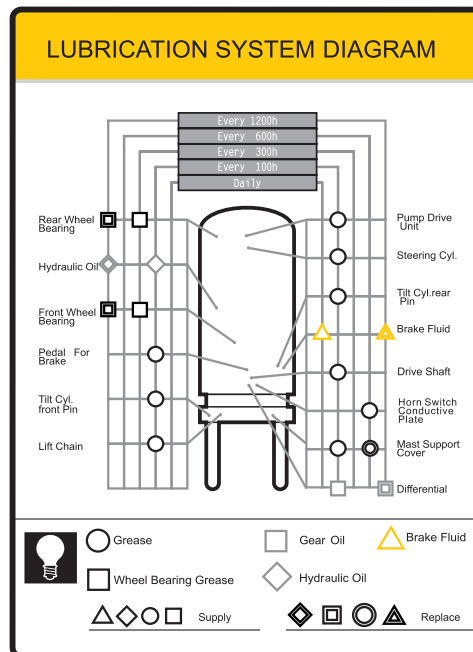

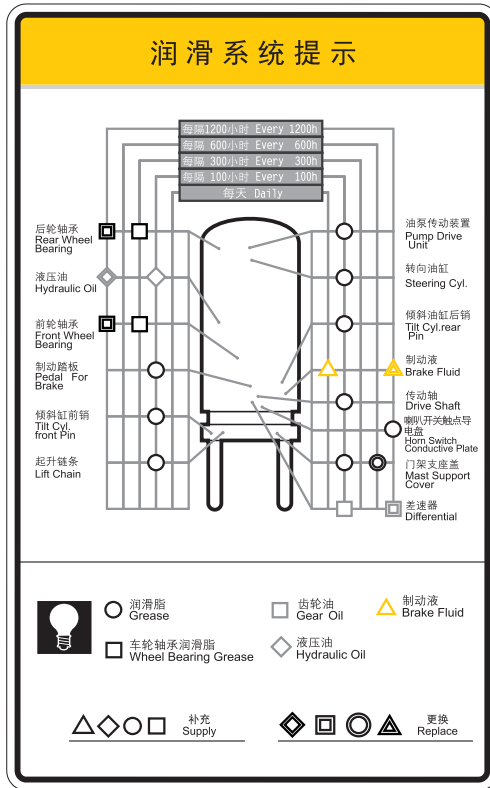
Note: for the truck with conductive plate type steering wheel.

(5) Decal of capacity chart

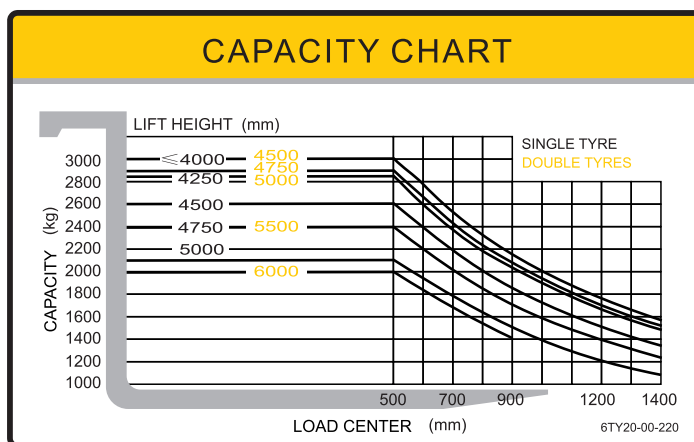

(6)Decal of caution before start

**⚠ CAUTION**

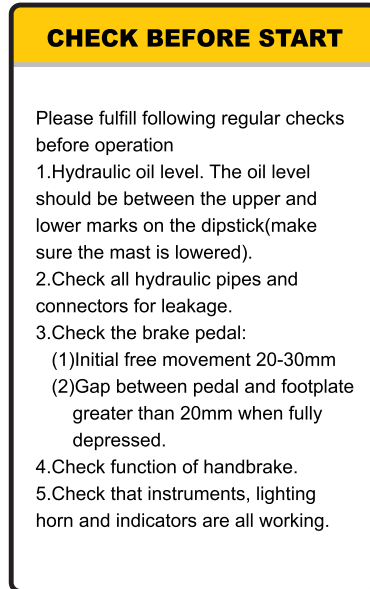

(7)Decal of hand brake adjustment

**⚠ CAUTION**

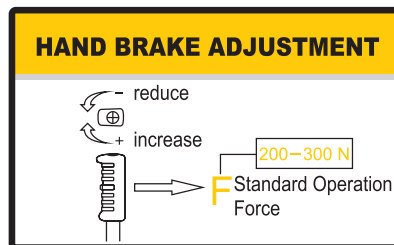

(8)Decal of adding hydraulic oil

**👉 NOTE**



(9)Decal of tyre safety(pneumatic tyres)

**⚠ WARNING**

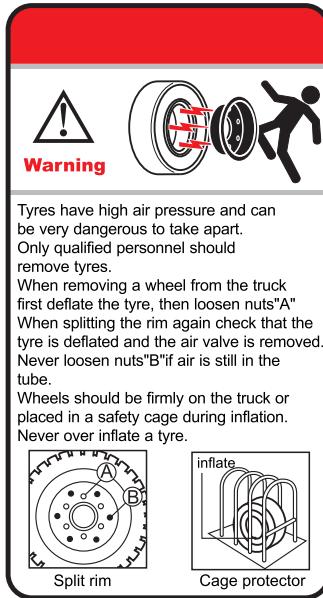

(10) Decal of sling

**⚠ CAUTION**



(11) Decal of no entry into the space behind the mast

**⚠ WARNING**



(12)Decal of tyre's air pressure

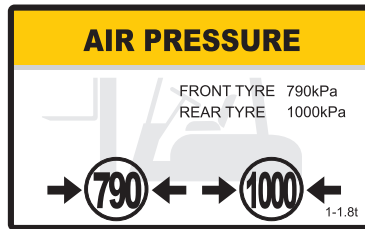

(13)Decal of mind your hands



(14)Decal of battery

BATTERY	
Model:	DA-500H
Weight:	1450-1540kg
Rated voltage:	80V
Rated capacity(C5):	500A.h
Dimension:	1145×585×765 (mm)
Specific gravity of the electrolyte(25℃):	1.285±0.005(g/cm³)

HELI			
Battery Style 蓄电池类型	LFP battery	Voltage 电压	48 V
Model 型号	IFP66/182/295	Capacity 容量	600 Ah
Serial No 出厂编号	2015年9月21日	Series No 单体数	15 S
Manufacture Date 出厂日期	2015年9月21日	Weight 重量	450 Kg

(15)Decal of routine battery use



**ROUTINE BATTERY USE**

1. Immiting appropriate distilled water or diluted vitriol slowly while replenishing electrolyte. The electrolyte level must be proper. The level exceeding is prohibited.
2. Open all lids of the battery and keep ventilated while charging.
3. Keep all lids close to avoid electrolyte splashing while use battery.
4. While changing battery, keep the battery box vertically.And lower it slowly to avoid electrolyte overflowing.
5. Clean the battery bracket regularly to avoid that the bracket is corrupted by electrolyte.

**Lithium battery using notes**

1. Please charge the battery with lithium battery special charger. It is prohibited to charge the battery with bad quality charger or other type charger;
2. Discharging temperature range: -25~50°C . Storage and long time operation below -25 °C or above 55 °C are prohibited;
3. Charging temperature range: 0-40°C . Please charge the battery after using at once in low temperature that is below 0°C ;
4. The battery should be away from severe environment such as high temperature, corrosive or dusty environment. Keep away from open flame or heat source;
5. After charging, close the charging protect opening cover and charging opening cabin door in turn. It is prohibited to close the door without closing the opening cover;
6. Stop using the truck at once when there is fault such as battery getting water, deformation, liquid leakage, wires naked and so on.
7. Press the emergency button when transporting, maintaining or not use for a long time; during normal operation, do not press the button unless there is an emergent case.

(16)Decal of routine battery maintenance



**ROUTINE BATTERY MAINTENANCE**

1. Be sure the battery voltage not less than 85% of the rated voltage while using.
2. The battery should be recharged within 24 hours, Never overcharge the battery during charging it.
3. Replenishing distilled water regularly to keep the electrolyte level normal.
4. If the battery is not in use for a long time, Please remember to recharge it once a month.
5. The battery temperature exceeding 55°C is strictly prohibited, keep away from flame to avoid explosion.
6. Keep the battery surface dry and clean.

**Lithium battery maintenance notes**

1. When the battery is lower than 20%. Charge it in time and it is prohibited to over discharge;
2. Charge the battery full after using. It is prohibited to over charge;
3. When the truck has to be stored for a long time, keep the battery electricity to be 40%~60%. Do not be full. Charge the battery before using;
4. Check the lithium battery charging socket regularly and make sure the frame is firm, the socket cover plate is well sealed, and the terminal inside of the battery is not rusty and has no foreign matters such as dust, rain and so on;
5. Keep the lithium battery dry and clean and it is prohibited to wash battery with water;
6. Make sure the battery be fully discharged and charged at least once a month.

(17)Decal of emergency button (only for the lithium battery powered forklift truck)



(18) Decal of No Water Flushing



(19) Decal of battery safety lock(for truck with side picking or side pulling battery)

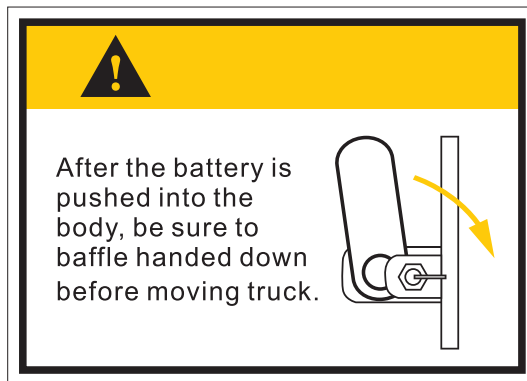

(20) Decal of mind your foot(for truck with side picking or side pulling battery)

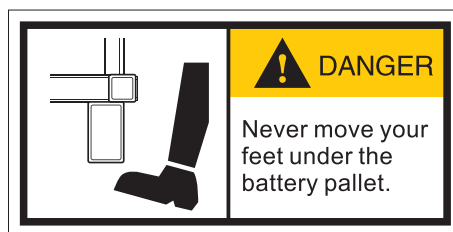

## II. OPERATION DEVICE & USE METHOD

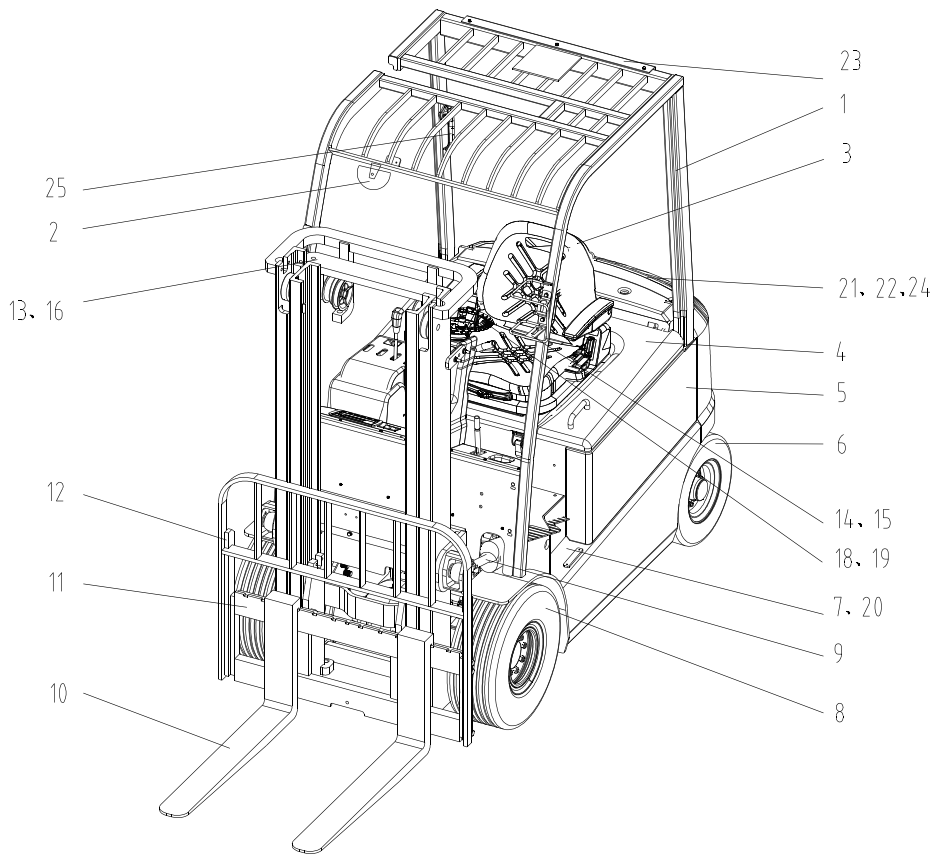

1.Overhead guard

3.Seat

5.Side board

7.Floor

9.Tilt cylinder

11.Lift bracket

13.Mast

15.Front combination lamp

18.Steering wheel

20.Floor

22.Rear board

24.Draw bar pin

2.Rear view mirror

4.Battery cover

6.Rear wheel

8.Front wheel

10.Fork

12.Load backrest

14.Head lamp

16.Lift chain

19.Instrument board

21.Balance weight

23.Rear combination lamp

25.Rear handle for horn button

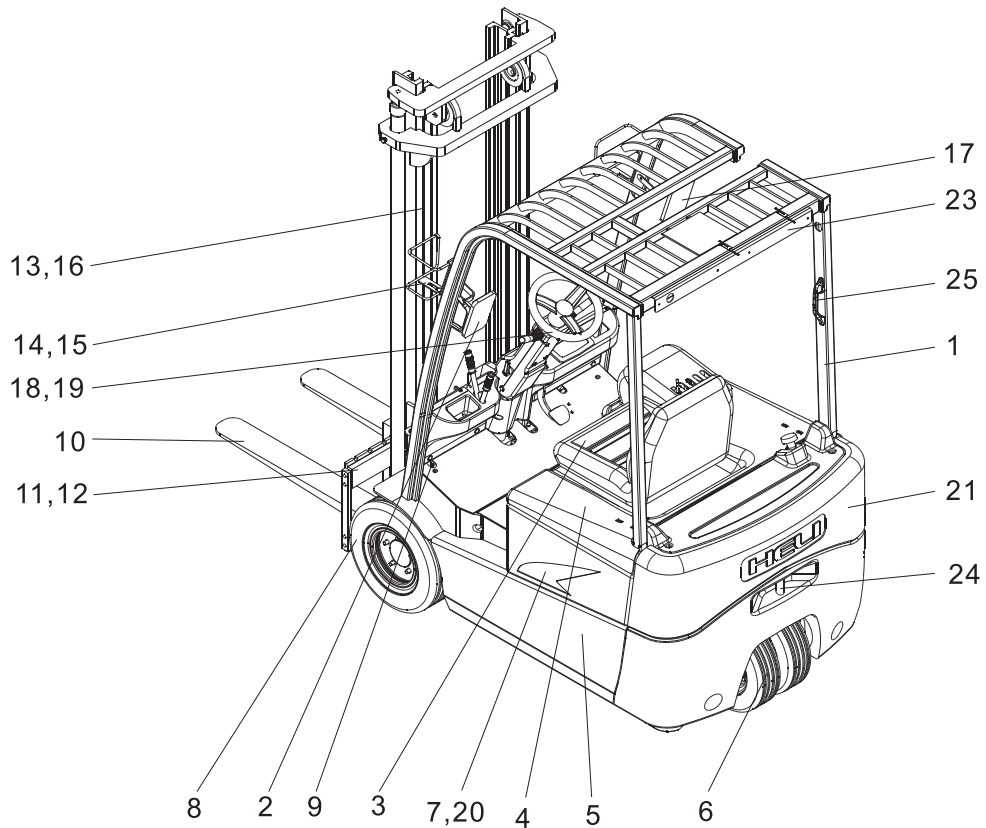

- |                                |                       |
|--------------------------------|-----------------------|
| 1.Overhead guard               | 2.Rear view mirror(L) |
| 3.Seat                         | 4.Battery cover       |
| 5.Side board                   | 6.Rear wheel          |
| 7.Floor                        | 8.Front wheel         |
| 9.Tilt cylinder                | 10.Fork               |
| 11.Lift bracket                | 12.Load backrest      |
| 13.Mast                        | 14.Head lamp          |
| 15.Front combination lamp      | 16.Lift chain         |
| 17.Rear view mirror(R)         | 18.Steering wheel     |
| 19.Instrument board            | 20.Floor              |
| 21.Balance weight              | 24.Draw bar pin       |
| 23.Rear combination lamp       |                       |
| 25.Rear handle for horn button |                       |

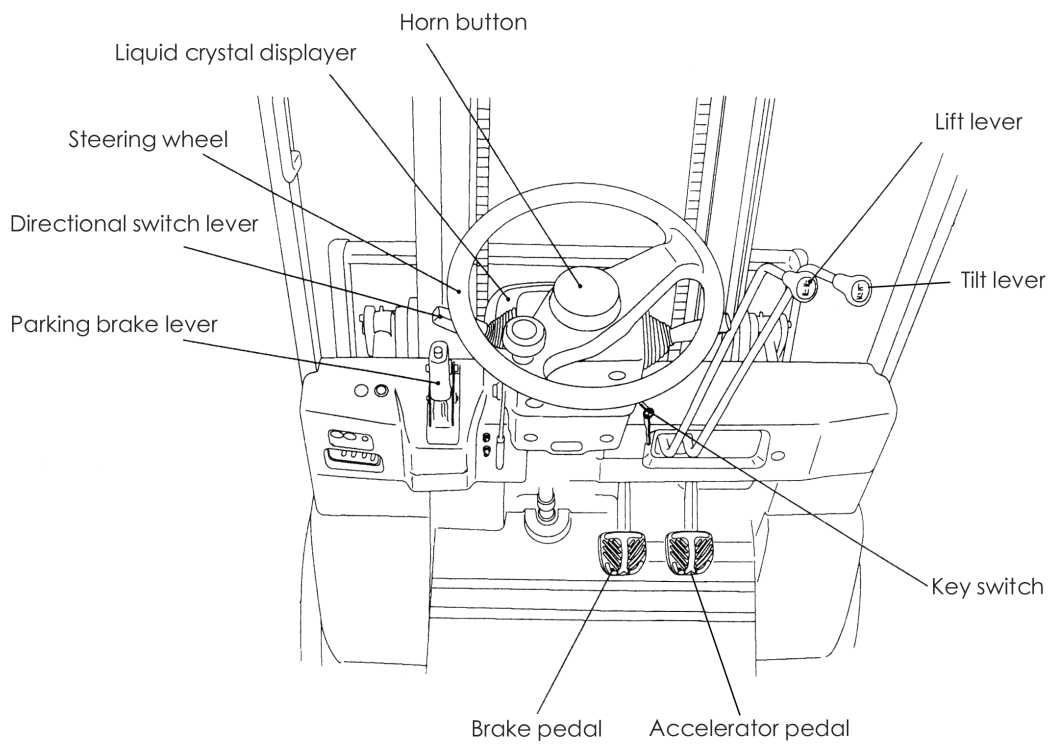

## 1.Liquid Crystal Displayer (ZAPI electric controller for AC)

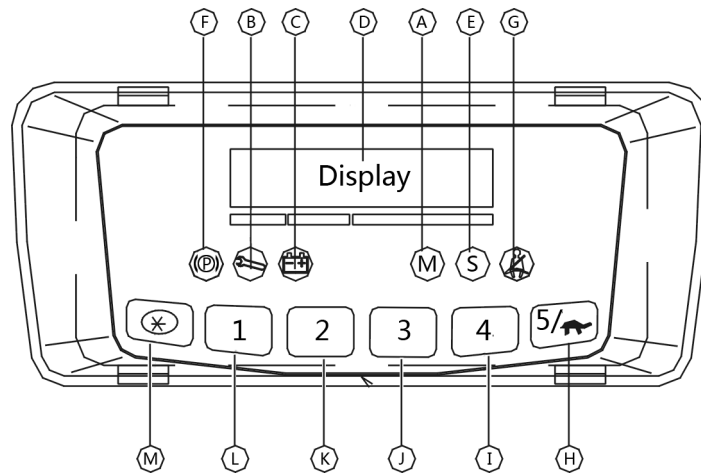

A: Moderate speed indicator

H: (High/moderate/slow)three speed mode choose/out hey

B: Fault LED

I: Set down Key

C: Low State of battery LED

J: Set up Key

D: LCD

K: Roll down Key

E: Slow speed indicator

L: Roll up Key

F: State of brake

M: Menu Key

G: warming lights for seat switch

(1) The main page, if there aren't alarms, shows battery charge, truck speed (Km/h) and traction hour meter ; if alarms are present it will show alarm code in the first row) and node number in which alarm has occurred. The alarm code will display on the first row. The node number will display on the second row. The node number will be described in ext chapters.

(2) By entering the service password from MAIN PAGE it's possible to have access to SERVICE MENU. Here with roll buttons (button 1 and 2 of membrane keyboard) it's possible to scroll the submenu items. If option CONSOLE ENABLE is ON with ENTER button (button \*of membrane keyboard) is possible to enter ZAPI CONSOLE submenu. From this menu is possible to choose which module of CANbus net (use buttons 1 and 2 to scroll and \* to enter) has to be connected to the display. When the display has been connected it works exactly like a Zapi digital console. Buttons of membrane keyboard do the same functions of Zapi console keys.

Button 5 performs function of the console key OUT

Button 4 performs function of the console key SET DOWN

Button 3 performs function of the console key SET UP

Button 2 performs function of the console key ROLL DOWN

Button 1 performs function of the console key ROLL UP

Button \* performs function of the console key ENTER

(3) Furthermore Smart Display has six built-in red led, which provide the operator with a easy information about the status of some truck devices. When  is pressed, speed mode is shifted among high speed mode, moderate speed mode and slow speed mode.

### Liquid Crystal Displayer (CURTIS electric controller for AC)

The Curtis enGage™ IV is a microprocessor based instrument panel that can be programmed to monitor, display and control numerous vehicle functions in a single integrated package.

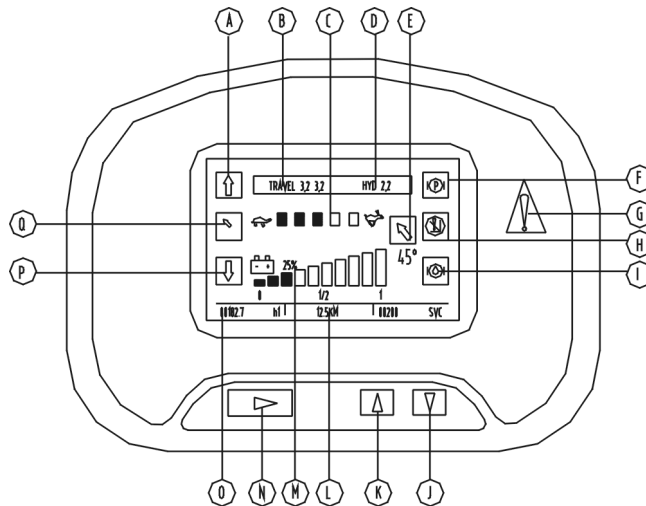

- A: Forward indication light
- B: Fault code of Traction controller
- C: Speed cutback direction
- D: Fault code of Pump controller
- E: Steering angle display
- F: State of brake
- G: Fault LED
- H: Lift lockout display
- I: Warning lights for brake fluid (no use)
- J: Selection button
- K: Selection button
- L: Speed display display
- M: Battery capacity display
- N: Menu Button
- O: Hour-meter display
- P: Backward indication light
- Q: Steering indication light

·Fault code

a)If this gauge is used with one traction vehicle, just one fault code will be displayed behind “TRAVEL”.

b) If this gauge is used for dual traction vehicle, two fault codes will be displayed behind “TRAVEL”, the left fault code is for master controller, and the right fault code is for slave controller.

c) In dual traction application, if there is no fault code from master and slave controllers, just one “OK” will be displayed behind “TRAVEL”; if one controller has the fault code, the other is no problem, both “OK” and fault code will be display on the same line.

d) The fault codes will be gotten from CAN or I/O input.

· Mode selection

a) Three mode selections will be: “ ”, “ ” and “ ”;

b) Button of “” is for mode selecting, and it is a cycle of these three mode selections if press this button continuously.

c) Mode selection information will be sent to traction controller via CAN.

· Speedometer and speed state

a) The speedometer will be displayed on Advisory 2 (bottom center), speed information supplied by AC controller, Monitor menu of “Vehicle Speed”, via CAN. Here “Vehicle Speed” is absolute value, gotten from traction controller or master controller.

b) Speed state: “”, AC controller sends to enGage IV some flags, and enGage IV will display different speed states based on these flags.

· Lift lockout

a) If BDI is used up, gauge will send a message to hydraulic controller and inhibit lift function, also “” will be displayed.

· Monitor menu

a) For traction controller or master controller, total 16 monitor variables will be displayed: “throttle command”% (0 ~ 100), “pedal switch”, “interlock switch”, “brake switch”, “parking switch”, “switch 6”, “forward switch”, “reverse switch”, “main contactor output”, “reverse light relay output”, “brake light relay output”, “motor RPM” RPM (0 ~ 6000), “motor temperature” °C (0 ~ 200) , “current (RMS)” A (0 ~ 800), “controller temperature” °C (0 ~ 200) and “vehicle speed” KPH (0 ~ 100).

b) For slave controller, total 4 monitor variables will be displayed: “motor RPM” RPM (0 ~ 6000), “motor temperature” °C (0 ~ 200), “current (RMS)” A (0 ~ 800), “controller temperature” °C (0 ~ 200).

c) For hydraulic controller (AC), total 15 monitor variables will be displayed: “throttle

command" % (0 ~ 100), "SS1", "interlock switch", " SS4", "SS5", "SS 6", "SS7/lower switch", "SS8/lift switch", "main contactor output", "reverse light relay output", "brake light relay output", "motor RPM" RPM (0 ~ 6000), "motor temperature" °C (0 ~ 200), "current(RMS)" A (0 ~ 800) and "controller temperature" °C(0 ~ 200).

·Program menu

a)Just for hydraulic controller (AC) application, setting two parameters: "Throttle Deadband" and "Throttle Max".

b)Indicate Monitor variable of "Throttle Pot" and apply the throttle, press " " when the value is appropriate for "Throttle Deadband".

c)Indicate Monitor variable of "Throttle Pot" and apply the throttle, press " " when the value is appropriate for "Throttle Max".

d)Display the parameter settings both of "Throttle Deadband" and "Throttle Max", and confirm whether these settings are same as what we needed.

## 2.Switches

(1)Key switch ⑪

OFF: This is the position where the switch is off and the key can be put in or taken off.

ON: Turning to right from the off position closes the switch to allow the operation of the truck.

### CAUTION

·Do not turn the switch on with depressing the accelerator pedal.

·Be sure to take the key off when leaving the truck.

·When parking the truck or charging the battery on the truck, remove the key.

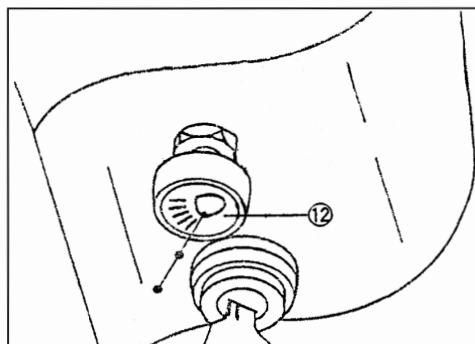
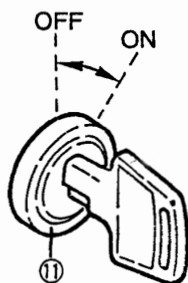

(2)Lamp switch ⑫

This switch is two step drawn.

Lamp \ Operation	OFF	1st step	2nd step
Width lamp	×	○	○
Tail lamp	×	○	○
Head lamp	×	○	○

○:lamp-on    ×:lamp-off

(3)Emergency button: it is installed on the right side of the seat or left side of the dashboard or right side of the dash board. Press the button in emergency to cut off the power.

(4)Seat switch: it is installed under the seat. The switch is on when the driver sits on the seat and travelling controller gets electricity or the truck can not move.

### 3.Controls

(1)Steering wheel ② and steering wheel knob①

The steering wheel is operated in the conventional manner, that is, when the wheel is turned right, the truck will turn to the right; when the wheel is turned left, the truck will turn to the left. The steer wheels are located at the rear of the truck. These cause the rear of the truck to swing out when a turn is made.

When steering, grasp the wheel knob by left hand, while the right hand is put either on the valve lever or the steering wheel lightly.

An electric power steering and a tilting handle are equipped for both a standard equipment.

#### NOTE

- Adjust the best angle corresponding to the operating position.
- After adjusting the tilt angle, lock the handle by tilt knob securely.

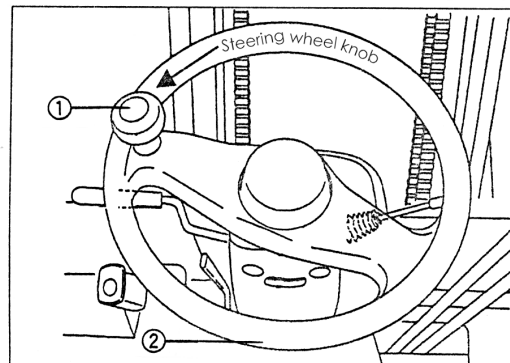
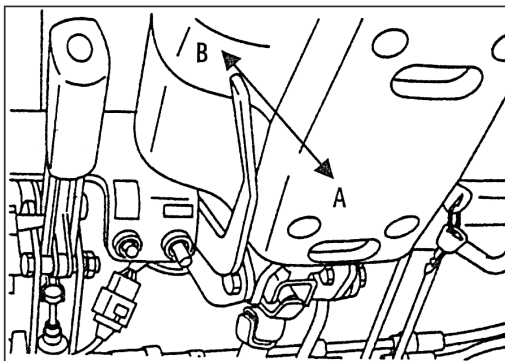

(2)Horn button④

Press the rubber cover at the center of steering wheel to sound horn.

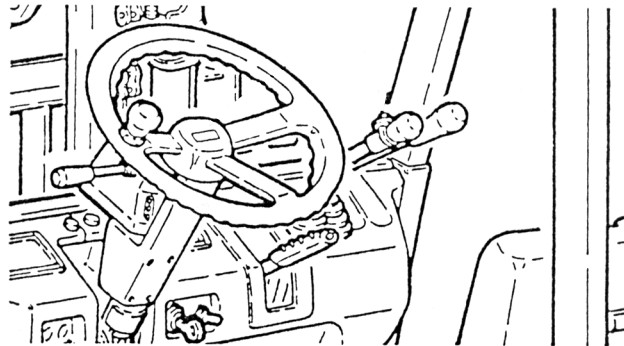

(3)Brake pedal ③ and acceleration pedal⑥

From left to right, there are brake pedal and acceleration pedal.

Brake pedal: Depress the brake pedal, the truck braked and the brake lamp shine at the same time.

Accelerator pedal: Depress the accelerator pedal softly. Truck's speed is controlled by depressing angle of the pedal.

 NOTE

·When depressing the brake pedal, make sure to release your foot from the accelerator pedal.

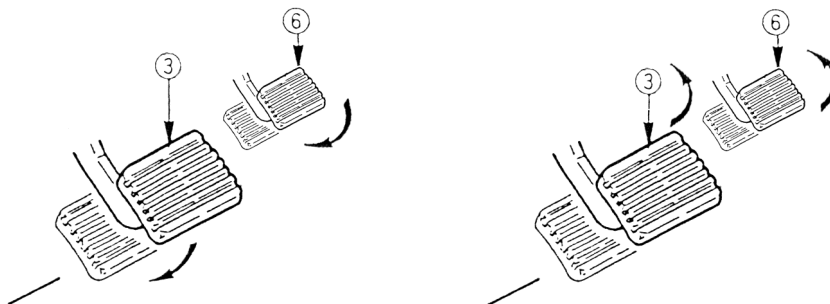

(4)Directional switch lever⑤

Indicate the traveling direction.

Forward traveling: Push the lever and depress the accelerator pedal.

Reverse traveling: Pull the lever and depress the accelerator pedal.

When parking the truck, return the directional switch lever to neutral.

**⚠ CAUTION**

·Do not depress the acceleration pedal at a stroke for avoiding a sudden start or a sudden acceleration

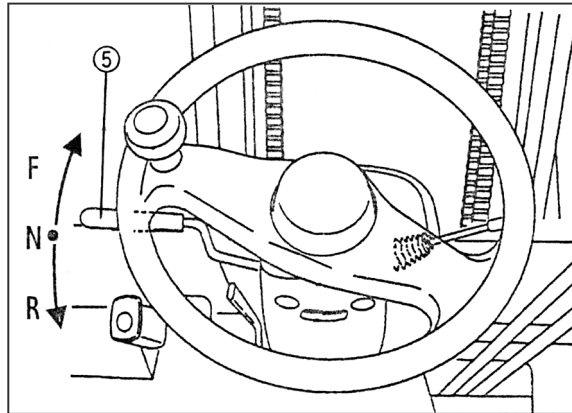

(5) Parking brake lever⑦

Prevent to move the truck, when park the truck, pull the parking brake lever fully.

In returning, push the parking brake lever to forward correctly.

**👉 NOTE**

·When operate the parking brake lever, depress the brake pedal.

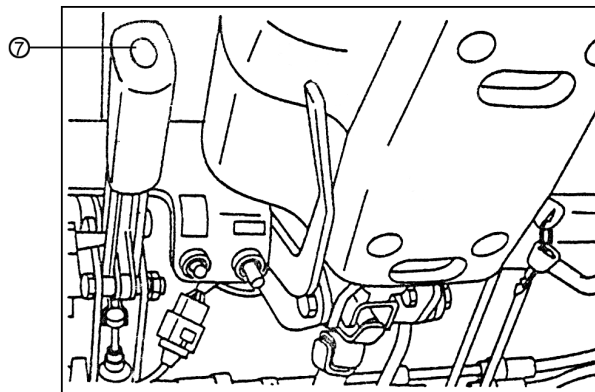

(6) Lift lever⑧

Pull the lift lever backward to lift up the forks. Push the lift lever forward to lift down the forks. The lift and lower speeds can be controlled by the tilt angle of the lever. The bigger the angle, the faster the speed.

**👉 NOTE**

·When turn the key switch on with pulling or pushing the lift lever, the lifting movement will not work.

·Do not make a sudden lowering and lowering stop.

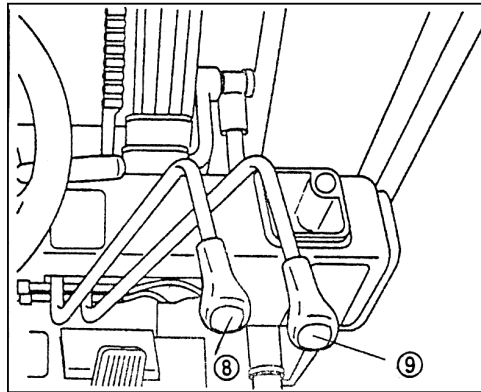

(7)Tilt lever⑨

Pull the tilt lever backward to tilt the mast backward. Push the tilt lever forward to tilt the mast forward. The backward and forward speeds can be controlled by the tilt angle of the lever. The bigger the angle, the faster the speed.

 **NOTE**

·When turn the key switch on with pulling or pushing the tilt lever, the tilting movement will not work.

#### 4.Body and Others

(1)Seat⑩

Adjust operator's seat to position which is comfortable for you and provides easy access to all hand and foot controls. The seat is unlocked by pulling the adjusting lever up. Before proceeding with work, adjust operator's seat and make sure that it is securely locked.

Adjustable position of the seat:(forward to backward):120mm.

 **WARNING**

1)The Use of Seat Belt:

·The seat belt is not allowed to be put under the arm and should be hung on the chest with the belt buckle reliably inserted into the buckle slot.

·The working structure of the seat belt is forbidden to be altered.

·The seat belt must be changed after serious crashing and rolling-over events.

·The seat belt must be changed when it is damaged, rips or becomes soft and deformed due to chemical reaction and sun light.

·The seat belt must be changed when its metal connecting part is bent, deformed

or rusted.

·The seat belt must be changed when its service performance is not so good.

2)If the truck is going to turn over, do not attempt to get out of the truck, because the speed of overturn is much faster than you. You should hold the steering wheel handle, and this practice will let you in the seats. Please tie safety belt.

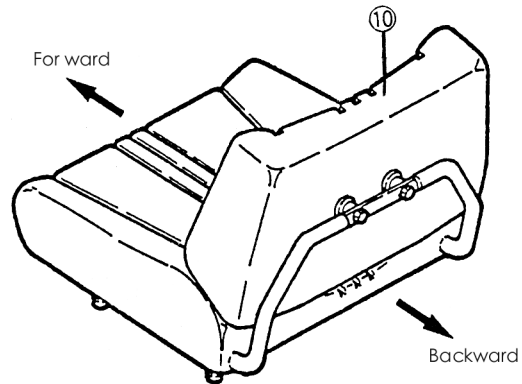

(2)Overhead guard

**⚠ WARNING**

·The overhead guard used is strong enough to meet safety standard, and protects the operator from falling materials. It's very dangerous to dismantle or rebuild the overhead guard, because these conditions could lead to an accident.

(3)Load backrest

**⚠ CAUTION**

·The load backrest is used to prevent the loads loading on the forks slide to the operator. It's very dangerous to dismantle or rebuild the load backrest, because these conditions could lead to an accident.

(4)Draw-bar pin

The draw-bar pin only used for following situation:

- While the truck can't moving.
- While transporting the truck.

**⚠ CAUTION**

·Do not operate the forklift truck as a tow tractor by using a draw-bar pin. Do not tow the forklift truck by other truck.

(5)Fork stopper

Fork stoppers are to lock the forks in position. To adjust fork spacing, pull up fork stoppers, turn, and shift the forks to the desired positions. The fork spacing should be adjusted according to loads to be handled.

**⚠ CAUTION**

·The forks should be set symmetrically to truck centerline and fork stoppers should always be set.

·When you adjust the fork spacing, depend your body on the load backrest, then push the forks with your feet. Do not push the forks with your hands.

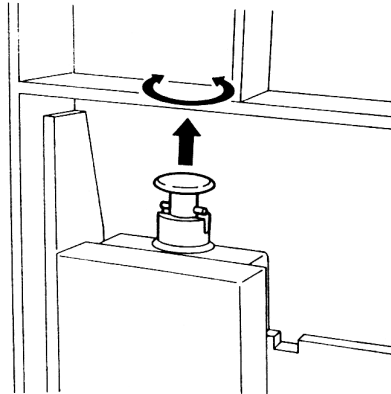

**(6) Safety step and safety gripe**

The safety steps are provided on both sides of the truck body. The safety gripe is provided on the front left pillar of the overhead guard. Use the safety step and safety gripe facing the truck when mount or dismount the truck.

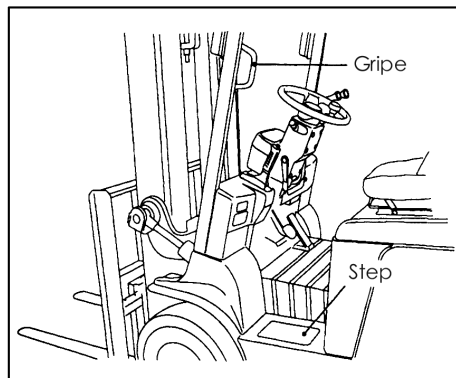

**(7) Fuse box**

The position of fuse box varies because of truck model. Normally, it is under the floor plate or on the rear plate of battery. Please adhere to the real product in case of discrepancy.

#### (8) Brake fluid reservoir

The brake fluid reservoir is on the battery front plate near oil tank or on the master cylinder of service brake or under the front floor plate.

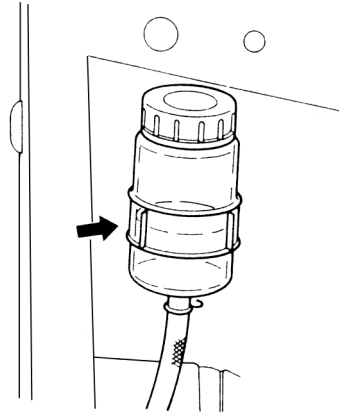

#### (9) Hydraulic fluid reservoir cap

According to hydraulic oil adding plate, add hydraulic oil from the oil adding hole on the hydraulic cover. There is oil level gauge on the hydraulic oil tank cover.

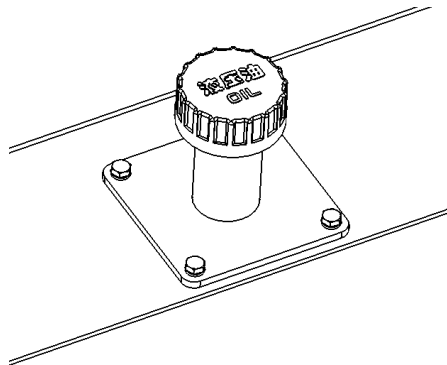

#### (10) Lamps

Two head lamps and combination lamps (turn signal, parking and clearance) are installed at the front side of the truck.

The combination lamps at the rear side serve as turn signal, tail lamp, brake lamp, parking lamp, back-up lamp and rear reflector.

#### **⚠ CAUTION**

·Take care of the lamps, and wipe dirt, if any, and replace any damaged lamp immediately.

·If you want to install the rear lamp, please contact the sale apartment of our company.

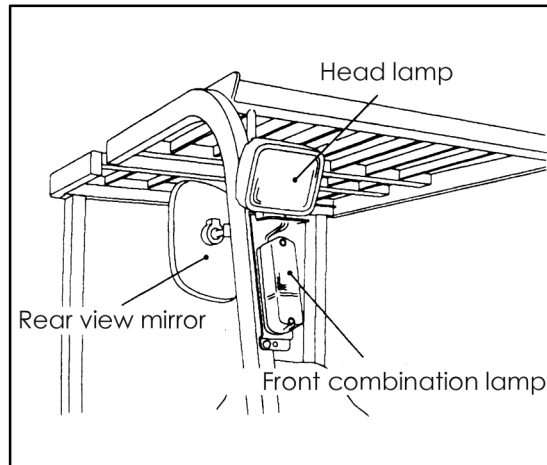

(11)Rear view mirror and rear handle for horn button

The rear view mirror is installed on the front leg of the overhead guard and both left side and right side have one rear mirror respectively. Or there is only one rear view mirror on the right front side of the overhead guard. Rear handle for horn button is installed on the right rear leg of overhead guard in order to sound the horn when backward to remind persons after.

**⚠ CAUTION**

- Keep the surface of the mirrors clean.
- Adjust the mirrors in order to see the rear area clearly.

(12)Lead-acid battery plug

The battery plug is used to connect or disconnect the battery to the electric parts of the truck. Under the normal cases, it is connected.

**⚠ CAUTION**

·When check the electric system, turn off the key switch and disconnect the battery plug.

·There is also some voltage in the main circuit when the key switch is in the “OFF” position.

·Do not disconnect the battery plug during operation, or the truck will not be able to turn.

·Please disconnect the plug of charger from the battery when charge.

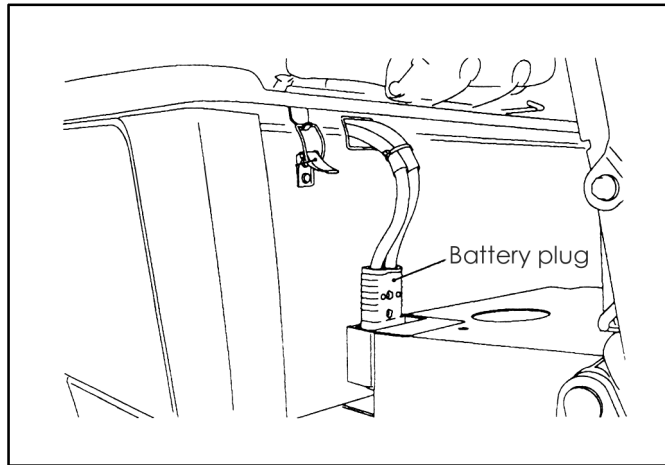

(13)Lithium battery charging spearhead and socket

Before charging, make sure there is no water or any foreign matters in the truck charging opening and charging spearhead. If there is, clean it before charging, or poor charging connection may cause over heat or even fire.



### III. DRIVING AND OPERATION

To operate the truck safely and get the most out of it, we describe the correct operating procedures on the following pages.

#### 1. During Break-in

We recommend to operate the machine under light load conditions for the first stage of operation to get the most from it. Especially the requirements given below should be observed while the machine is in a stage of 200 hours of operation.

#### ⚠ CAUTION

- Always warm up your machine before putting it to work...irrespective of season.
- Perform specified preventive maintenance services carefully and completely.
- Avoid sudden stop, starts or turns.
- Oil changes and lubrication are recommended to do earlier than specified.
- Don't run engine at high rpm without load need lessly.

#### 2. Relationship Between Load and Stability of Truck

The lift truck keeps the balance of weight between the truck body and the load on the forks with the center of the front wheels as a fulcrum when the rated capacity load is placed in position. Due care should be paid to the weight and the center of gravity of loads to maintain the stability of the truck.

#### ⚠ WARNING

· If the rated capacity is exceeded, there is a danger of the rear wheels being raised and in the worst case, the truck will turn over, resulting a fatal accident. As seen from the above sketches, the load placed near the fork tips practically has the same effect that the weight of the load is increased. In this case, the load weight is reduced accordingly.

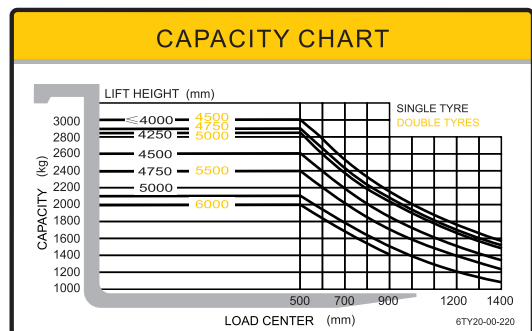
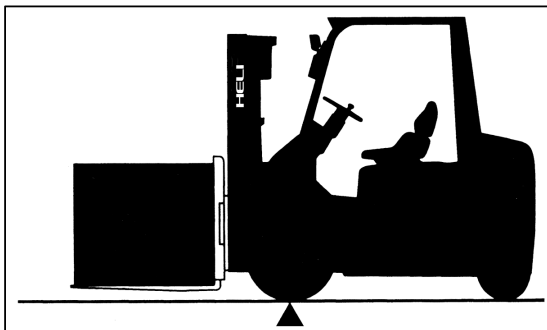

### 3. Load Center and Rated Load

The load center is the distance from the front face of the forks to the center of gravity of the load. The chart given above shows the relation between the load center and the weight of loads to be allowable for the 2 ton lift truck (Allowable Load). The load Chart will be attached onto the truck. Replace damaged or missing load chart with new one.

#### **WARNING**

**If a truck is equipped with a load-handling attachment such as a side shifter, load grab or rotating clamp, its allowable load is reduced as compared with that of a standard truck (without any attachment) due to the following reasons.**

1) The load equal to the weight of attachment is reduced.

2) Since the width of attachment causes the load center to move forward the allowable load is reduced on the same principle as a seesaw.

The installation of attachment causes the load center to move forward, which is called "lost load center".

Never exceed the allowable load indicated on the load chart attached onto the truck or attachment.

### 4. Stability of Forklift Truck

The stability standard of lift trucks is specified by the ISO or other standards. However, the stability stated in these standards is not applicable in all operating conditions. The stability of your lift truck varies according to the operating conditions. In the following operating conditions, the maximum stability is secured:

1) Ground or floor is level and hard.

2) Traveling under standard unloaded or loaded condition.

Standard unloaded conditions: This means that the forks or other load engaging means are raised 30cm above the ground and the mast is tilted fully backward without loads.

Standard loaded conditions: This means that the forks or other load engaging means are raised 30cm above the ground and given capacity loads at the basic load center on it and the mast is tilted fully backward.

#### **WARNING**

**Use minimum forward and reverse tilt when stacking and unstacking loads. Never tilt forward unless load is over stable stack or rigid rack or at low lift height.**

### 5. Transporting and Loading the Truck

(1) Transporting the truck

#### **CAUTION**

·When transporting the truck, riggings are used to fix the truck as well as blocks are to be inserted under the wheels to prevent the vehicle from moving in carriage.

·The truck's length, width, height should be cared when loading it, unloading it or transporting it on the road. And all rules must be complied with.

(2)Loading and unloading the truck

**⚠ CAUTION**

·Please use the dockboard with enough length, enough width and enough strength to load and unload the truck.

·Apply the parking brake effectively and prevent the wheels from moving.

·Fix the dockboard on the center of trailer, and there must be no grease on the dockboard.

(3)Hanging up the truck

**⚠ CAUTION**

·Hang up the truck by trained person.

·Hook the wire at the appointed position.

·Use wire rope which has a sufficient strength.

·The battery, mast and balancweight of the truck also have there appointed hang up position.

## 6.Preparation for Start

(1)Check the directional switch lever position

Put the directional switch lever to the neutral position.

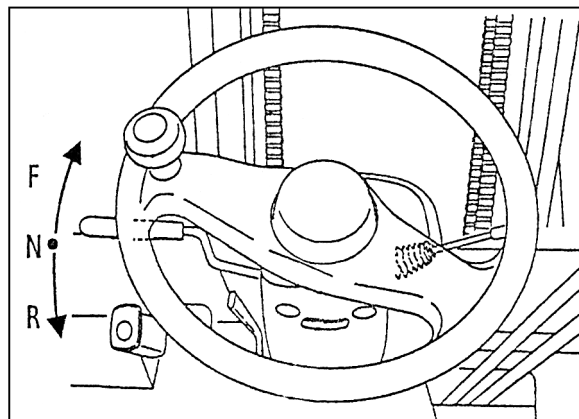

(2)Turn on the key switch

Grasp the steering wheel knob. Then turn on the key switch.

**⚠ CAUTION**

- After turning the key switch on, it costs one second to start the truck.
- Before turn the key switch on, the directional switch lever should be turned to neutral.
- Don't depress the accelerator pedal at a stroke for avoiding a sudden acceleration.

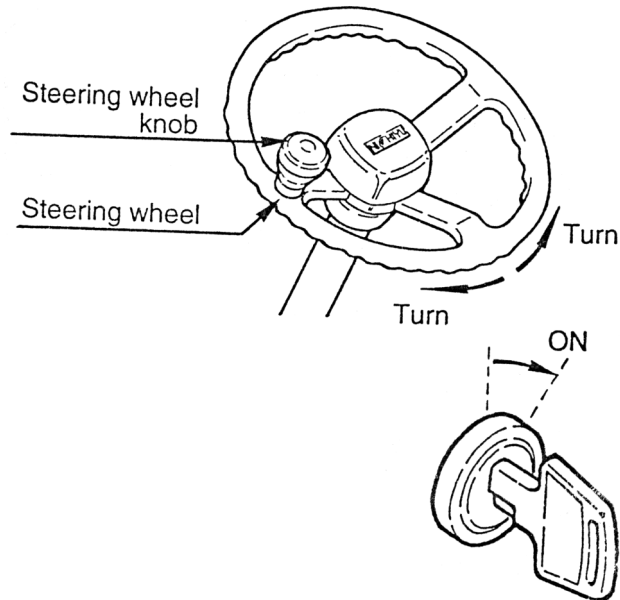

(3)Tilting back the mast ass'y

Lift up the forks about 150-200mm from the floor by pulling backward the lift lever.

Tilt back the mast ass'y by pulling backward the tilt lever.

(4)Operation of the directional switch lever

Operate the directional switch lever to moving direction(forward·backward).

Forward: Push the lever forward.

Backward:Pull the lever backward.

(5)Taking off the parking brake

Depress the brake pedal.

Push the parking brake lever forward fully.

Or in the negative parking brake system, it disengages the brake by hydraulic pressure automatically when you depress the accelerator pedal.

Grasp the steering wheel by left hand, put right hand lightly on the steering wheel.

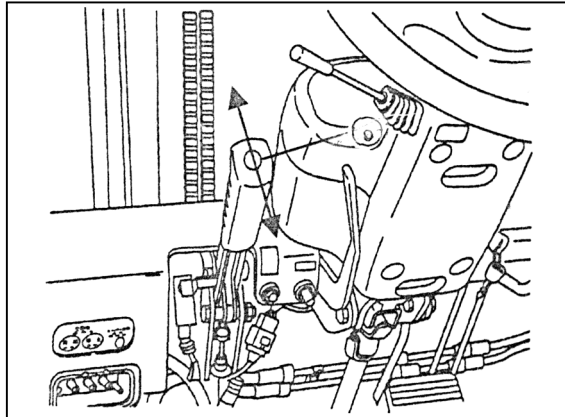

## 7. Driving

### (1) Start

Take off your foot from the brake pedal and depress the accelerator pedal gradually, then the truck will begin to move.

Acceleration varies in accordance with the depth of the accelerator pedal depressed.

### **⚠ CAUTION**

**·Do not a sudden start and stop. A sudden start and stop will cause the load falling.**

### (2) Slow down

Reducing depressing of accelerator pedal slows down travel speed.

### **⚠ CAUTION**

#### **Slow down when**

- a) Turning a corner**
- b) Approaching a load or pallet**
- c) Approaching storage**
- d) Narrow aisle**
- e) Floor/road condition is bad**

**·When travelling backward, you must look behind to ensure rear safety. Depending on backview mirror only is dangerous. If the truck is assembled with rear handle for horn button, use it when travelling backward.**

### (3) Turning

A forklift truck is different from a car, because of the rear wheel steering. Slow down and operate steering wheel paying careful attention to swing of the truck's rear end.

### (4) Stopping

Slow down and apply the brake slowly.

**⚠ CAUTION**

- Do not apply brake suddenly. A sudden stop causes a load falling.
- When apply brakes suddenly on a full traveling speed, it makes the driver bend forward and hitting to the steering wheel.



(5) Parking

Park the truck in an out-of-traffic area and.....

- a)Apply the parking brake by pulling up on the parking brake lever.
- b)Down the forks on the ground.
- c)Place the key switch in “OFF” position.
- d)Remove the key and keep it.
- e)Be careful while mounting and dismounting.
- f)Please enable the park when the operator leaves the chair without key off, otherwise the system will give the alarm with the error code on the display.

**⚠ CAUTION**

·Safe parking

- a)Park your truck on a level ground-preferably in a wide area. If parking on a slope is unavoidable, position the truck so that it cross the slope and block the wheels to prevent accidental roll.
- b)Park your truck in a designated area or out-of-traffic. If necessary, put a signpost or signal lights around the truck.
- c)Park your truck on a hard ground. Avoid soft ground, deep mud or slippery surfaces.
- d)If you can not lower the forks on the ground due to break-down of the loading system, put a caution cloth to the fork end and park in an out-of-traffic area.

**⚠ WARNING**

- Check for slippery steps and floor.

·Don't dismount from the moving truck.

·Never jump off the truck.

(6)Repairing of disabled forklift truck

**⚠ CAUTION**

·If the truck occur failure suddenly during operation, please tow it away for repairing immediately.

**8. Battery's Using Method**

(1)Lead-acid battery charging

Charge the battery with the proper charger and operate it according to the stipulations in the Operation & Service Manual for the charger.

a)Do not run out of the battery's electrolyte

**⚠ CAUTION**

·The minimum quantity of electrolyte should be kept. If the quantity is short, it causes overheating or burning of the battery.

·When the electrolyte of battery is in short supply, its life will be shorten.

·For battery compartment without liquid leakage hole, check if there is hydrops inside of compartment every month. If there is electrolyte spillage caused by improper adding of distilled water, please clean the hydrops in the compartment with sucker in time.

Check the electrolyte once a week.

b)Replenishment of refined water or distilled water

Refer to Operation & Service Manual of Battery.

c)Prohibition of overcharging

d)Being well ventilated place

**⚠ CAUTION**

Charge the battery at a place where is well ventilated and does not get wet with in the rain.

e)Open the battery cover

**⚠ CAUTION**

When charging the battery, hydrogen gas is occurred. Open the battery cover under charging, make it not being closed.

f)Check for terminal, cable and plug

**⚠ CAUTION**

·Prior to charging, check if the plug and cable are not damaged.

·Do not charge the battery which has condition as following.

—The electrode of plug is damaged.

—The terminal and cable are rusted.

**These cause sparks, damages of burn and ignite explosions.**

g)Charging after turning off the key switch

h)Check for specific gravity

Measure the specific gravity of all cells before charging.

Any abnormality within the battery could be found and an accident prevented by knowing the specific gravity before and after charging.

i)Pulling out or putting on the plug should be done by holding plug itself not cable.

**⚠ CAUTION**

·Do not pull cables.

·When cable or plug has damaged. contact sale apartment of our company.

**Replace it.**

j)Discontinuance of charging

**⚠ CAUTION**

·When discontinue the charging of battery, operate it according to the stipulations in the Operation & Service Manual for the charger.

·When pull out the plug of charger under charging, it causes sparks which is dangerous.

( 2 ) Lithium battery charging

Charge the lithium battery with HELI specified charger and please follow the charger OPERATION AND SERVICE MANUAL strictly.

·Charge the battery after turning off the switch.

·Please charge the battery at a safe condition ( avoid charging if there is liquid or fire.)

·There should be equipped with fire extinguishing devices such as sand and dry powder extinguisher for emergent fire extinguishment.

·Make sure there is no foreign matters such as dust and water in charger and socket. If there is, clean it before charging, or poor connection between charger and socket may cause over heat even fire.

·Do not modify or disassemble charging port and charging equipment or fault or fire may be caused.

·Keep the following precautions during charging in order to avoid serious harm:

a) Do not contact charging terminal or terminal inside of the charging spearhead.

b) When there is lightning, do not charge the battery or touch the truck. if it is hit by the lightning, charging equipment may be damaged and human injury may occur.

·When charging is finished, do not disconnect charging equipment with wet hand or standing in water, or electric shock may occur and human injury may be caused.

·When charging is finished, close the battery charging opening cover to prevent foreign matters falling into the opening during travelling or opening is easy to be damaged.

·When the electricity quantity is lower than 20%, charge the battery in time. No over discharging.

·Charge the battery after using. Charge the battery full. No over charging.

·Pay attention to the following things to avoid the damage of charging equipment:

a) Do not close the charging opening cabin door without close the charging opening cover.

b) Do not pull the or twist charging cable.

c) The charging equipment should not bear shock.

d) Do not store or use the charging equipment when the temperature is higher than 50°C.

e) It is prohibited to disconnect the charger when there is current output or electric arc may be produced which will cause person injury or property loss.

f) Keep the charging equipment away from the heater or other heat sources.

Step 1: charging preparations

(1) Turn off the key switch. Refer to figure 1(a).

(2) Take the charging spearhead down from the charging equipment (note: there is integrated button lock catch on the spearhead, see figure 1(b), press it down and then taking down). Check if the charger and lithium battery charging socket has foreign matters or water; check if the metal terminal is rust or corrosive. See figure 1(c) and (d).

(3) There is power switch at the rear side of the charging equipment. Turn on the power switch and then power indicator is on. The meter is displayed as figure 2. Because the charger is not connected to the truck at that time, charging equipments is standby or power off.

(2)Exchanging battery

When truck is continued to operate over a working shift and battery energy is consumed, change the battery with another battery which is charged fully at the time of shift and then charge the dismounted battery fully.

### CAUTION

·When exchange a battery, make sure that the battery should match with the truck. When use a battery which does not match with the truck, it causes a shortage of



(a) turn off the key switch

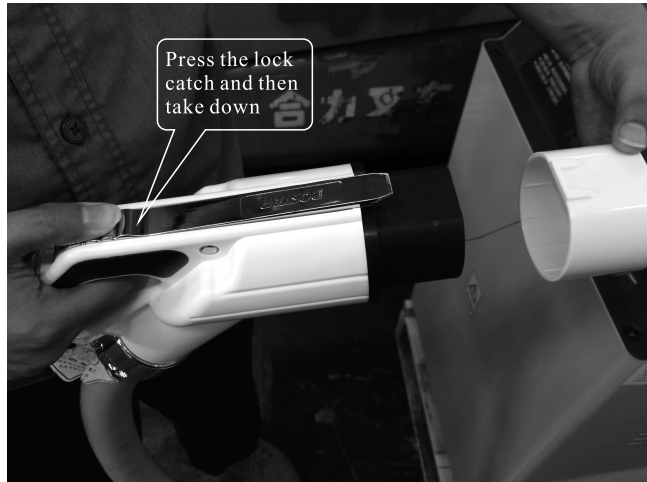

(b) lock catch



(c) spearhead check

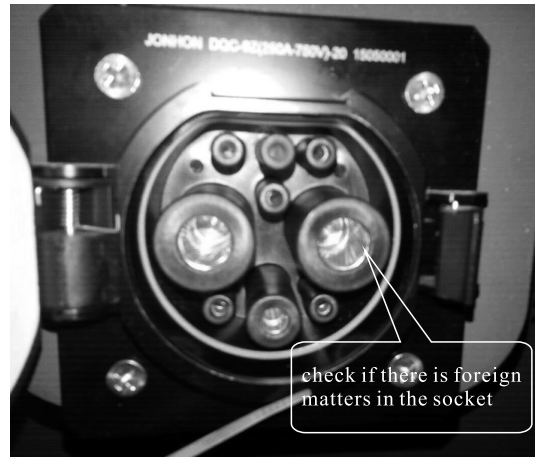

(d) socket check

Figure 1 spearhead check and socket check



Figure 2 meter display when standby

## Step 2 Charging connection

Insert the charging spear head into the lithium battery charging socket. Then the charging equipment will automatically check and communicate with lithium battery. when the whole system has no fault, the charging equipment internal relay will connects after 15s and charging begins. The charging indicator turns on and information such as charging voltage, current, charging time and charging fault will be shown on meter. See figure 3.



Figure 3 Normal charging display

## Step 3: Disconnection after charging

When the battery is fully charged, the charging equipment will stop charging automatically. Output voltage and output current are all 0. See figure 4. Then press the stop button and then charging spear head can be taken down. See figure 5. If it has to stop charging when the battery is not fully charged, press the stop button and take down the spear head until the current is reduced to 0.

Note: please not press emergency button to stop charging unless necessary.



Figure 4 Display when the charging is finished

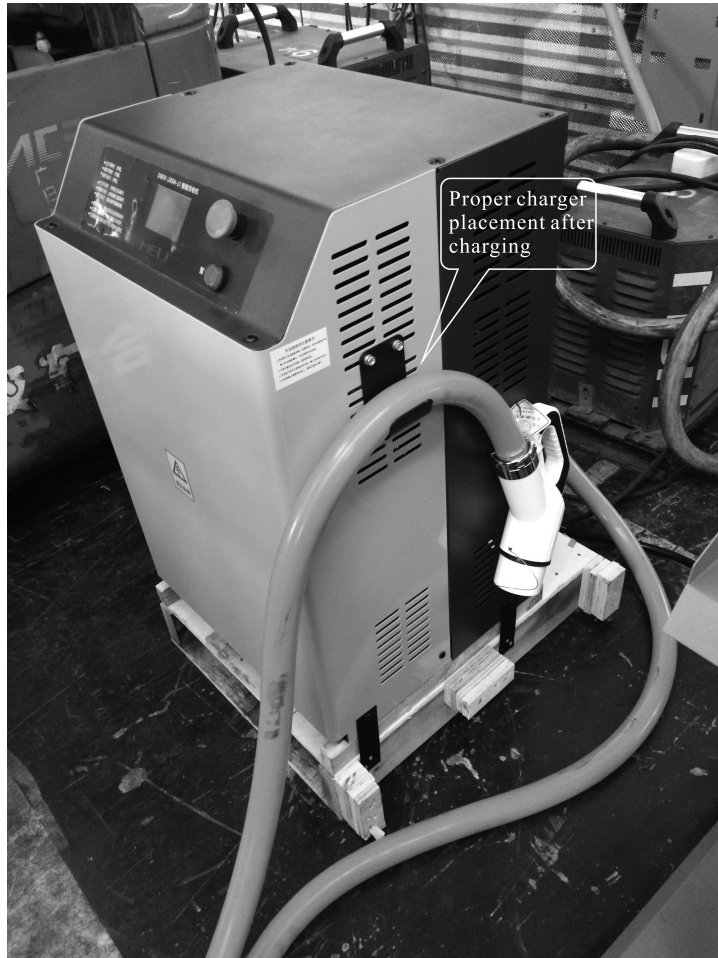

Figure 5 charging is finished

**working or a turnover of truck under traveling.**

**·Exchanging battery should be done on a flat floor.**

Exchanging the battery should be done by observing the following instruction.

**⚠ CAUTION**

**·When exchange the battery by operating another forklift truck, provide suitable slings (attachment).**

**·Hanging the battery should be made by specified personnel.**

a) Disconnect the battery plug.

b) Open the battery cover.

Locking the battery cover by gas spring or others to avoid the falling down of the cover, the injury of people or damage of the truck body.

c) Loose the fixed unit of the battery.

d)When lifting the battery box out of the truck, care must be taken not to hit the steering wheel or others.

e)After installing a full charged battery, fix it and connect the battery plug securely.

f)Close the battery cover.

**⚠ CAUTION**

·Care must be taken not to squeeze your fingers when open or close the battery cover.

·When hang up the battery box, care must be taken not to hit at the frame with swinging it.

**Special note: For trucks with side picking or side pulling battery, make sure that the battery guard is put down and the lock handle is tighten to ensure that there is no shaking clearance in horizontal direction after the battery is replaced. The battery shall lie against the left limit position.**

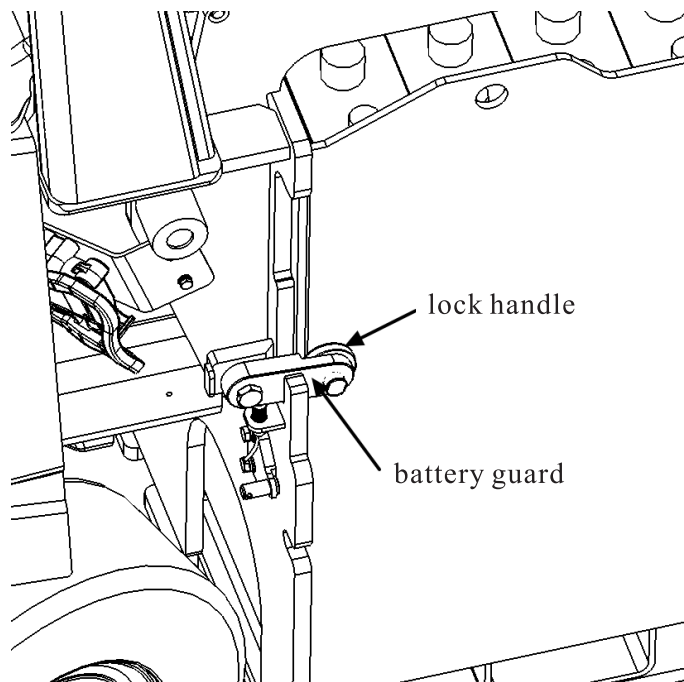

### 9.Stacking Operation

**⚠ CAUTION**

**Check the following items before starting operation of truck.**

- Make sure that there is not load's falling and damage of load at loading area.
- Make sure that there is no objects and stacking is carried out safely.

When stacking a load, observe the following procedures.

- (1) Slow down the travel speed when approaching a stacking area.
- (2) Stop the truck in front of stacking area.
- (3) Check for safety around the stacking area.
- (4) Adjust the truck position which a load (pallet) locates in front of the stacking area.
- (5) Tilt the mast to vertical position and lift up the forks above the stacking position.
- (6) Check the stacking position and move forward and stop slowly at the proper position.
- (7) Make sure the load is just above the stacking position and lower the forks slowly. Make sure the load stacked correctly.

 **NOTE**

**When the load is not aligned at front/rear ends of the load or pallet:**

**a) Lower the forks until the load weight on the forks becomes free.**

**b) Move the truck backward about 1/4 length of the forks.**

**c) Lift (50-100mm) the forks again and move to forward then lower the load slowly at a proper stacking position.**

(8) Check clearance backward and move backward avoiding hitching forks to pallet or load.

(9) Make sure the tips of forks are off the load or pallet, and lower the forks to the position for running (150-200mm above the floor).

**10. Picking Operation**

When picking up the loads, observe following procedures.

(1) Slow down the traveling speed when approaching a load to be picked up.

(2) Stop the truck in front of the load (about 30cm between the load and the fork

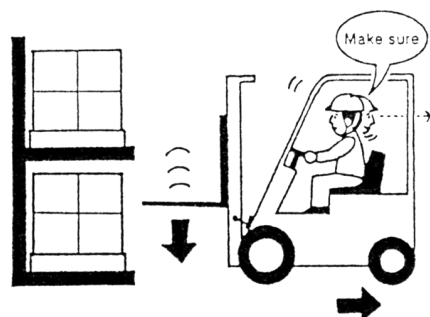
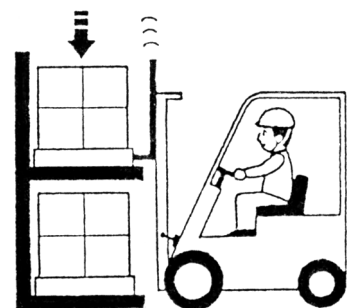
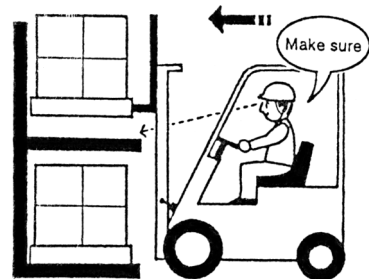
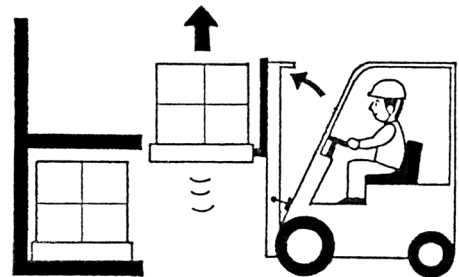

tips).

(3) Adjust the truck position which a forks locates in front of the load.

(4) Make sure safety of the load which is not collapsed.

(5) Tilt the mast to vertical position.

(6) Check the inserting position and move the truck forward slowly until the forks are fully inserted into the pallet.

### NOTE

**When it is difficult to insert the forks fully into the pallet:**

**a) Insert the forks by its 3/4 length and lift up the pallet a little (50-100mm), and draw out the pallet about 100-200mm and lower the pallet again.**

**b) Insert the forks fully into the pallet.**

(7) After inserting the forks, lift up the pallet (50-100mm).

(8) Check the clearance and move the truck backward until the load is lowered.

(9) Lower the load up to 150-200mm above the floor.

(10) Tilt the mast backward for stabilizing the load.

(11) Carry the load to its destination.

### 11. Storing

(1) Before storing

Before storing your lift truck, clean it thoroughly and perform inspection using the following procedures.

a) Wipe away grease, oil, etc. adhering to the body of the truck with waste cloth, and use water, if needed.

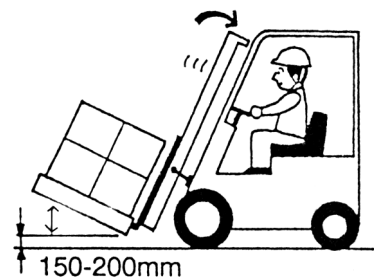
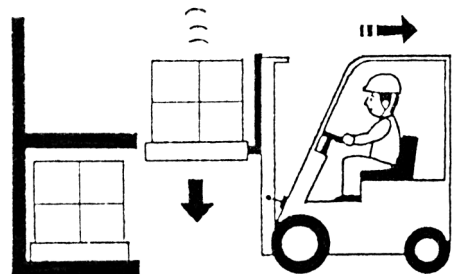
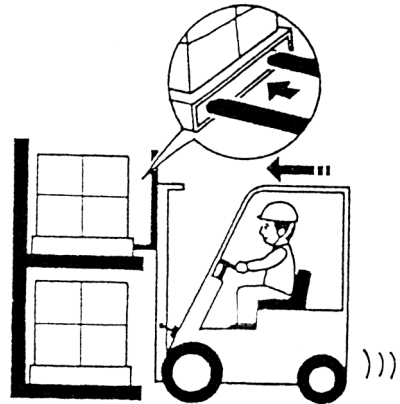
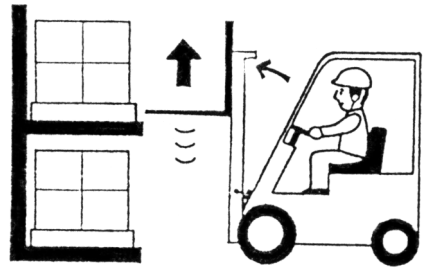

- b) While washing the truck body, check general condition of the truck. Especially check the truck body for recess or damage and tires for wear or nails or stones in the tread.
- c) Check for leakage of hydraulic oil, engine oil, fuel, or coolant.
- d) Apply grease, where needed.
- e) Check for looseness of hub nuts, cylinder piston rod joints.
- f) Check mast rollers to see that they rotate smoothly.
- g) Prime oil into the lift cylinders by actuating the lift cylinders at the full stroke.

**⚠ WARNING**

**If at any time your lift truck is found to be in need of repair, defective, or in any way unsafe, the condition should be reported to the supervisor, and the truck should be taken out of service until it has been restored to safe operating condition.**

(2) Daily storage

- a) Park the lift truck at a specified place and block the wheels.
- b) Place the shift lever(s) in the neutral position and apply the parking brake securely.
- c) Remove the key and keep it sure.

(3) Long time storage

Perform the following service and checks in addition to the “DAILY STORING” services.

a) Taking the rainy season into consideration, park the machine at a higher and hard ground.

b) For lead-acid battery truck, dismount the battery from the machine. Even though the machine is parked indoors, if the place is hot or humid, the battery should be kept in a dry, cool place. Charge the battery once a month.

For lithium battery truck, when the truck has to be stored for a long time, keep 40%-60% electricity, do not be full and press the emergency button. During storage, charge the battery according to lithium battery manual. Charge the battery full before operation. Lithium battery self discharging is affected by environment temperature and humidity. High temperature and humid temperature will speed up battery self discharging. The battery is suggested to be stored under -10°C-45°C dry environment.

c) Apply antirust to the exposed parts such as cylinder rods and shafts which tends to rust.

d) Cover components such as the breather and air cleaner which may be caught with humidity.

e) For lead-acid battery truck, the machine should be operated at least once week. Fill

the cooling system, if the cooling water is discharged, and mount the battery. remove grease from the cylinder rods and shafts. Start the engine and warm up thoroughly. Move the machine a little forwards and backward. Operate the hydraulic controls several times.

For lithium battery truck, make sure the battery be charged and discharged at least once.

f) Avoid parking on soft grounds such as an asphalt ground in summer.

(4) To operate the forklift truck after a long time storage

a) Remove antirust from the exposed parts.

b) Discharge foreign matter and water from the hydraulic oil reservoir.

c) Charge the battery and mount it on the machine. Connect the cables.

d) Perform pre-operational checks carefully.

## **12. Washing the Truck**

(1) No washing the truck and the battery with water

a) It is absolutely forbidden to wash the cable, the connector and the plug.

b) For lead-acid battery, when adding water to battery, impurity will enter into battery from liquid adding port which will badly affect battery service life. Acidic water after washing will pollute environment. Please blow the battery with air and clean with cloth. If this can not be done, ask professionals to do it. Take out the battery to do this and install until the water on the outside of the battery is dry.

For lithium battery, keep its surface clean and dry. It is prohibited to wash the battery with water.

(2) No washing the electrical system with water ( including but not limited to the following items: )

a) The controller, the contactor

b) Motors (driving motor, bump motor)

c) DC

d) Battery, the battery plug

e) The display

f) The accelerator

(3) The most point of cleaning the truck

a) Apply the parking brake securely.

b) Turn the key switch to “OFF” and take out the battery plug from the truck.

(4) After washing the truck

a) Drying the truck by using compressed air.

b) Before operator the truck, running it to be sure if it is well.

### **13. How to Move a Disabled Lift Truck**

#### **WARNING**

**Use extra care when towing a lift truck if there is a problem with any of the following:**

- (1) Brakes do not operate correctly.**
- (2) Steering does not operate correctly.**
- (3) Tires are damaged.**
- (4) Traction conditions are bad.**
- (5) The lift truck must be moved on a steep grade.**

If the steering pump motor does not operate, steering control of the lift truck can be slow. This can make the control of the lift truck difficult. If there is no electrical power, there is no power steering. Do not tow the lift truck if there is no power. Poor traction can cause the disabled lift truck or towing vehicle to slide. Steep grades will require additional brake force to stop the lift truck.

Never carry a disabled lift truck unless the lift truck **MUST** be moved and cannot be towed. The lift truck used to carry the disabled lift truck **MUST** have a rated capacity equal to or greater than the weight of the disabled lift truck. The capacity must be for a load center equal to half the width of the disabled lift truck. See the nameplate of the disabled lift truck for the approximate total weight. The forks must extend the full width of the disabled lift truck. Center the weight of the disabled lift truck on the forks and be careful not to damage the under side of the lift truck.

#### **How to Tow the Lift Truck**

- (1) The towed lift truck must have an operator.
- (2) Tow the lift truck slowly.
- (3) Raise the carriage and forks approximately 0.30 meters from the surface. Install a chain to prevent the carriage and mast channels from moving.
- (4) If another lift truck is used to tow the disabled lift truck, that lift truck must have an equal or larger capacity than the disabled lift truck. Install an approximate half-capacity load on the forks of the lift truck that is being used to tow the disabled lift truck. This half-capacity load will increase the traction of the lift truck. Keep the load as low as possible.
- (5) Use a towing link made of steel that attaches to the tow pins in the counterweights of both lift trucks.

#### IV. PERIODIC INSPECTION & SERVICING

Complete inspections of the forklift truck prevents faults previously and extends an usable period of the truck. Hours shown below are based on 8-hour operation per a day and 200-hour operation per a month.

##### **⚠ CAUTION**

- **Only trained and authorized serviceman shall be permitted to service the truck.**
- **Inspection prior to operation, inspection of after operation, weekly servicing and monthly servicing are all could be done by the operator.**
- **Heli pure components and parts are requested to be used in addition to the spare parts of original engine manufacturer.**

##### **1. Inspection Prior to Operation**

Inspecting the truck prior to operation should be done for safety operation and keep good condition of the truck. This is a duty in law. When there is fault, contact the sale apartment of our company.

##### **⚠ CAUTION**

- **A small fault could cause a serious accident. Do not operate or move the truck prior to finishing repair works and inspect.**
- **Inspecting trucks should be made on a flat floor.**
- **Trucks in need of inspection to electrical system shall have the key switch turned off and the battery disconnected prior to such inspection.**
- **The improper dealing with the waste oil, For example pipe it to a drain or the soil or burn the waste oil, will pollute water, soil and air. It is banned by law.**

(1) Check points and contents

	No.	Check points	Contents
Braking system	1	Brake pedel	Depth of foot brake pedal and braking force
	2	Brake oil	Quantity and stain
	3	Parking brake	Pulling depth of lever and operation force in positive parking brake system. Ensure the hydraulic pressure which actuated on parking brake spring in the negative brake system.
Steering system	4	Play of steering wheel	Loosened, play and/or vertical movement
	5	Power steering operating	Operating of all parts
Hydraulic system & mast	6	Function	Function, any crack, lubricant
	7	Oil piping	Oil leakage
	8	Hydraulic oil	Appropriate quantity
	9	Lift chains	Equal tension of chains on R.H. and L.H.
	10	Solenoid for brake and lower mast	Measure it is ok or not.
Wheel	11	Tyres	Air pressure, abnormal wearing and/or damage
	12	Hub nuts	Securely tighten
Battery	13	Charging	Confirmation of state of battery capacity indicator and specific gravity, plug is securely connected
Lamps & horn	14	Head lamps, tail lamps, back lamps, turn signal lamps and horn	Turn on and off, sound
Monitor & lamps	15	Function	When key switch is turned on, "MONITORING OK" is displayed
Others	16	Overhead guard, load backrest	Fitting bolts and nuts are tighten
	17	Others than the above	Any abnormality

(2) Inspection procedure

a) Check of foot brake pedal

Check performance of brake and make sure that it is over 50mm from the floor plate when depressing the brake pedal fully.

Proper braking distance without a load is about 2.5m.

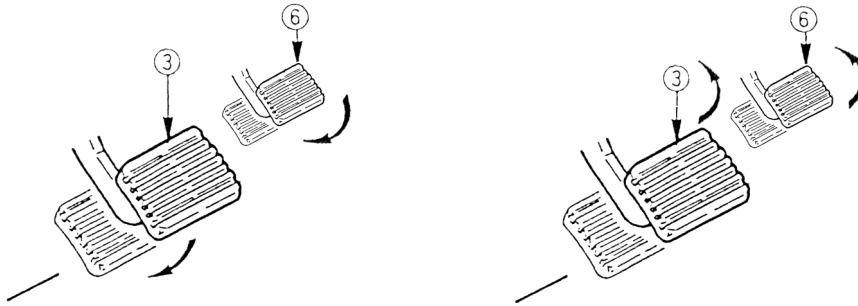

b) Check of brake oil

**⚠ CAUTION**

·Remove the cap of brake oil tank and check the quantity and condition of the brake oil.

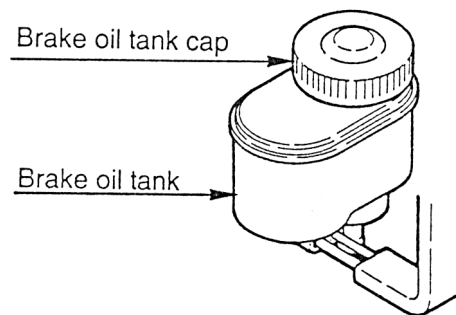

c) Check of parking brake lever

Pulling the parking lever and to see:

- Suitable pulling stroke
- Braking force
- Damaged parts

Lever operation force(standard 17-22kg)is suitable for operator or not.

Adjustment should be done by a screw which located on the top of lever.

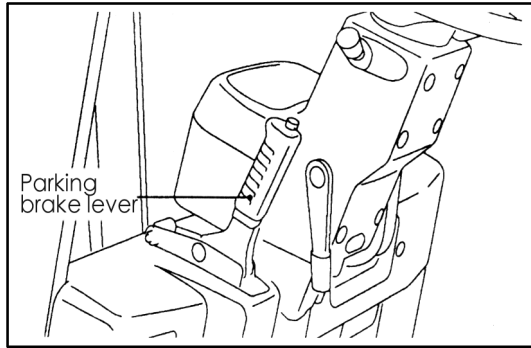

d) Check of play of steering wheel

Turn the steering wheel clockwise and counterclockwise lightly and check to see if there is play. Appropriate play is 50-100mm. The steering wheel can be adjusted forward and backward for a certain angle.

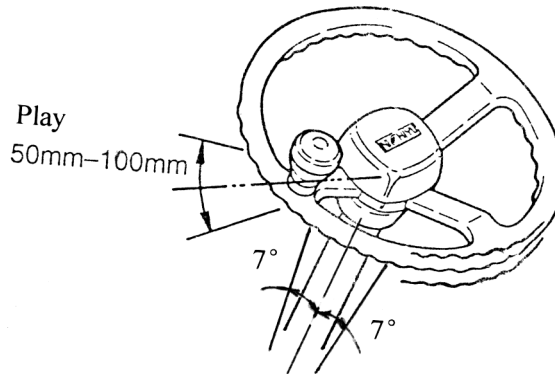

e) Check of power steering function

Turn the steering wheel to clockwise and counterclockwise, check the power steering operation.

f) Check of function

Check if lifting and tilting operation are smooth.

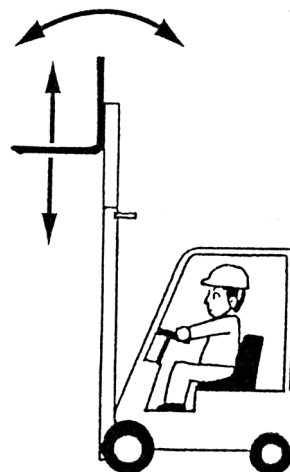

g) Check of oil piping

Check for any oil leakage from the lift cylinders, tilt cylinders and oil piping.

h) Check of hydraulic oil

Check oil level, using the oil level dip stick with the forks lowered on the floor.

Appropriate oil quantity is within the range of H to L.

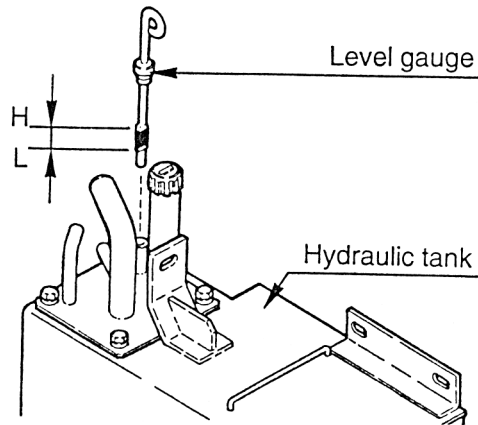

i) Check of lift chains

Lift up forks by 200-300mm above the floor, and make sure lift chains are equivalent in tension.

Check the finger bar if it does not decline either to right or left side. If the tension is different, adjust using the chain anchor bolts.

**⚠ CAUTION**

·After having adjusted, tighten up the double nuts securely.

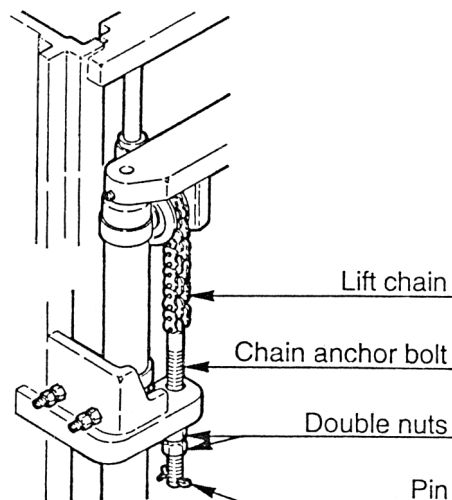

j) Check of tyres (pneumatic tyres)

Measure the air pressure by using the tyre gauge after removing the cap. After checking air pressure, make sure air does not leak from the valve before replacing the cap.

**⚠ CAUTION**

**Air pressure for forklift truck is higher than a normal car, do not raise the pressure over the appointed pressure.**

Standard Air Pressure		kPa				
Models Tyres	H3 series			G series		
	1-1.8t	2-2.5t	3t	1-1.8t (1-1.5t)	2-2.5t	3t
Front	790	860	830	860	1030	970
Rear	860	900	900	860	900	970

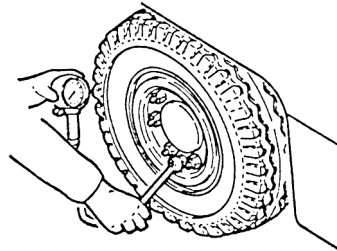

Check of tyres (solid tyres)

Check the tyre and its side face if there is any damage or craze. Check the rim if there is any distortion or damage.

k) Check of hub nuts

Check if the hub nuts are loose by tightening them with a box wrench.

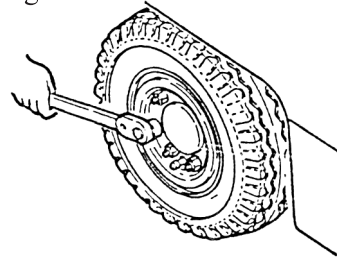

l) Check of charging

Measure the specific gravity of battery. When they show 1.275-1.285 at 30°C conversion, the battery is full charged. And check the terminals which are loose and the cable which is damaged.

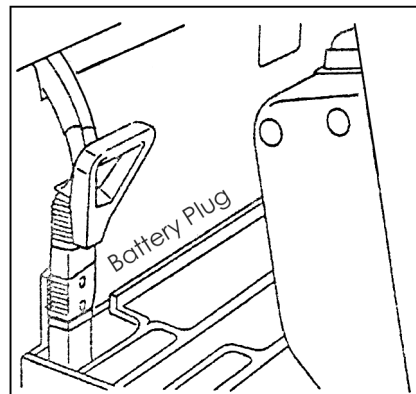

m) Check of head lamps, turn signal lamps and horn

Check if lamps turn on. Check if horn sounds.

Turn Signal Lever

L	Left turn
N	Neutral
R	Right turn

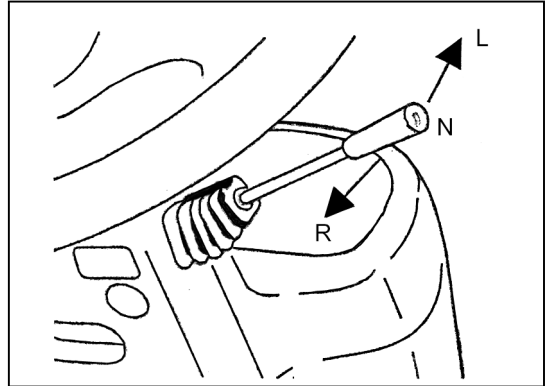

The horn sounds when pressing the part shown by the arrow.

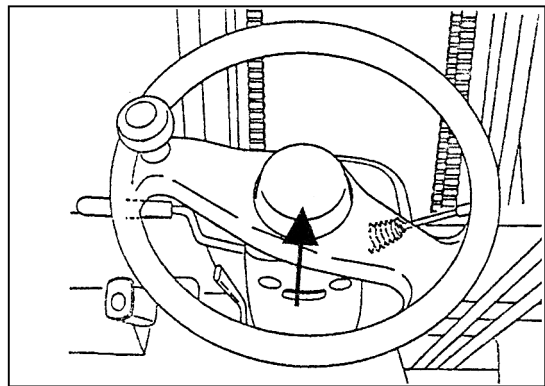

n) Check of meter

The meter will be display as shown in the figure after the key switch is on for several seconds normally.

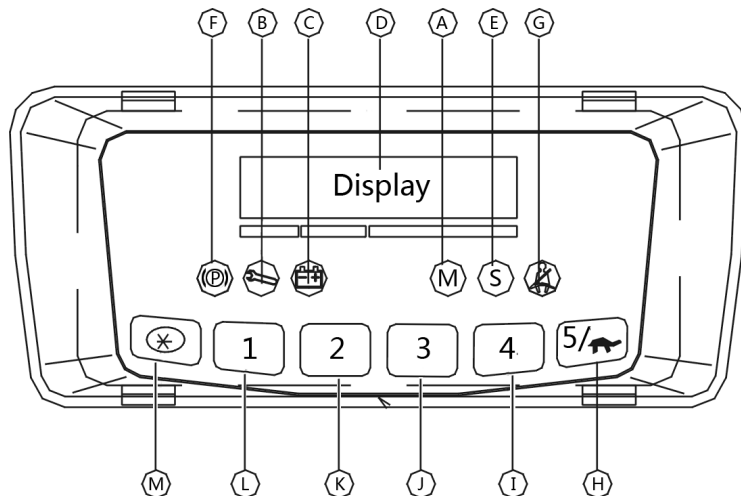

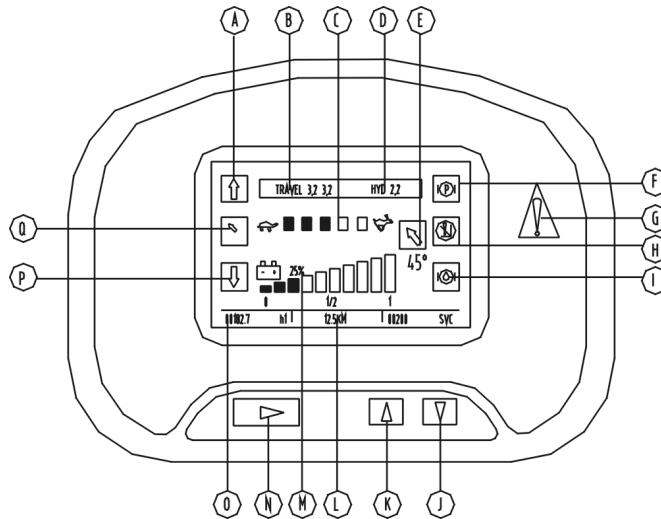

- o) Check of overhead guard and load backrest  
Check if any fitting bolts or nuts are not loosen.
- p) Others  
Check for any other abnormality.

**⚠ CAUTION**

**Be sure to turn off the key switch and disconnect the battery plug while checking electric system except turning on the lamps and checking operation.**

**2. Inspection After Operation**

When close working, remove stains on the truck and inspect the truck as following items.

- (1) Deterioration or leakage at all parts.
- (2) Deformed, distorted, worn or cracked members.
- (3) Apply grease in accordance with condition.
- (4) Lift forks to the maximum lift height of the truck several times after operation. (When the maximum lift height was not used in the day's operation, the operation provides oil to cover at internal cylinders for preventing rust.)
- (5) Verify an abnormal part which observed any defects during operation.

**⚠ CAUTION**

**A small fault could cause a serious accident. Do not operate or move the truck prior to finishing repair works and inspect.**

**3. Weekly (50-hour) Servicing**

Inspect the following servicing in addition to the inspection prior to operation.

Check points	Contents
Electrolyte quantity	Check the electrolyte level. When the level is low, replenish with refined water.
Specific gravity of electrolyte	Measure the specific gravity and temperature of electrolyte of all sells.
Cleaning of battery	Clean the top of uncovered batteries and vent caps.
Check of contactors	Polish the roughness of the contact by a sand paper.

**⚠ CAUTION**

**Be sure to disconnect the battery plug when inspecting the electrical system.**

(1)Check for quantity of electrolyte

**⚠ CAUTION**

- After completed the replenishment, close the vent caps securely.
- Do not replenish over the water. Flooding could make an electric shock.

(2)Check for specific gravity of electrolyte

Measure the quantity and specific gravity of all cells.

Normal:When all sell's specific gravity are the same figure as converted figure at 30, it is normal.

Abnormal:When the specific gravity is less than 0.05 from the average figure of others, it is abnormal.

(3)Cleaning of battery

Keep dry condition by wiping off with a wet cotton cloth to protect corrosion at the connecting area of top batteries.

**⚠ CAUTION**

- Cleaning of the battery should be done before charging.
- Wear rubber gloves and boots to prevent a electrical shock.
- Handle the battery plug not to touch water.

The inside of vent caps will be stained. Clean them as following procedures.

a)Remove the vent caps.

b)Wash the inside of vent caps with a neutral cleaner.

c)Install the vent caps.

**⚠ CAUTION**

**Make sure the vent caps are closed securely.**

(4)Check of contactor

Put in a sand paper between the contacts and push the movable contact to close and then draw out the sand paper. Repeat this procedure.

**4.Monthly(200-hour) Servicing**

Carry out the following service besides the weekly(50-hour) maintenance.

As a result of inspection, when adjustment or replacement should be necessary, call serviceman of our company.(Record of monthly maintenance should be kept.)

System	No.	Check points and contents		Note
Truck	1	General	Distortion, Crack and abnormal noise	
	2	Horn	Sound	
	3	Accessories(Head lamp, turn signal lamp)	Function	
Battery, Charger & Electric system	4	Battery electrolyte	Quantity,specific gravity and clean	
	5	Terminal plug	Damage and clean	
	6	Key switch	Function	
	7	Contactors	Contact and function	
	8	Microswitch	Function	
	9	Controller	Function	
	10	Traction motor(Brush, commutator)	Wearing and spring force	DC system
	11	Hydraulic motor(Brush, commutator)	Wearing and spring force	DC system
	12	P.S. motor(Brush, commutator)	Wearing and spring force	DC system
	13	FET chopper unit	Current limitation and function	
	14	Fuses	Looseness and capacity	
	15	Wiring, terminal	Damage and looseness	
Drive, Steering, Mast, Hydraulic & Braking system	16	Steering wheel	Play and movement	
	17	Steering link	Lubrication	
	18	Gear case	Oil quantity,leakage and abnormal noise	
	19	Fitting nuts for tyres	Looseness	
	20	Tyres	Damage and wearing	
	21	Lift chain	Lubricant and tension	
	22	Cylinder rod guide pins	Looseness and damage	
	23	Lift bracket	Adjustment,lubricant,crack and distortion	
	24	Forks	Crack and transformation	
	25	Lift rollers	Adjustment and lubricant	
	26	Mast rollers	Adjustment and lubricant	
	27	Outer mast, inner mast	Jolt	

System	No.	Check points and contents		Note
	28	Lift cylinder	Oil leakage	
	29	Tilt cylinder	Oil leakage	
	30	Control valve	Function and oil leakage	
	31	Hydraulic tank	Oil quantity and leakage	
	32	H.P.hoses	Oil leakage and transformation	
	33	Overhead guard,load backrest	Damage,crack and transformation	
	34	Brake linkage	Lubricant and movement	
	35	Parking brake lever	Adjustment and lubricant	
	36	Bolts and nuts	Looseness	bolts for installation of mast, front axle, rear axle, balance weight, tyre and so on.
	37	Powr steering	Function	

### 5. Every Three-month(600-hour) Servicing

At the same time with the every three month (600-hour) servicing, repeat the sequence of monthly (200-hour) servicing. When adjustment or replacement of part should be necessary, call qualified serviceman of our company.

Check points	Contents
Contactors	Polish up the roughness of the contact with sand paper.
	When roughness is excessive, replace it.
Motors	Wearing of the carbon brushes.

### 6. Semiannually(1200-hour) Servicing

At the same time with the semiannually (1200-hour) servicing, repeat the sequence of every three monthly (600-hour) servicing. When adjustment or replacement of part should be necessary, call qualified serviceman of our company.

Check points	Contents
Contactors	When roughness of the contact is excessive, replace it.
Motors	Wearing of the carbon brushes.
Front axle	Change of gear oil.
Hydraulic oil	Strain and change of hydraulic oil.
Oil filter	Cleaning the oil filter.
Brake oil	Stain and change of the brake oil.
Conductive plate of steering wheel	Add special lubricating grease (for the truck with conductive plate type steering wheel).

 **NOTE**

· **Inspection of carbon brush**

**Raise up the whole spring and then pull out the carbon brush to check. Check if the surface of the commutator is rough and wearing has gone over the wearing limitation.**

Model	Applied	H	Wearing limit	Q'ty
CPD10-CPD30	Traction	28mm	15mm	8
	Hydraulic	28mm	15mm	8
	Power steering	22mm	12mm	8



## V. OTHERS

### 1. Lubrication Points and Recommended Oil

#### (1) Lubrication point

- : Replace                      FO: Hydraulic oil
- : Replenishment          GO: Gear oil
- : Check and adjust      CG: Chassis grease
- BO: Brake oil                W: Refined water

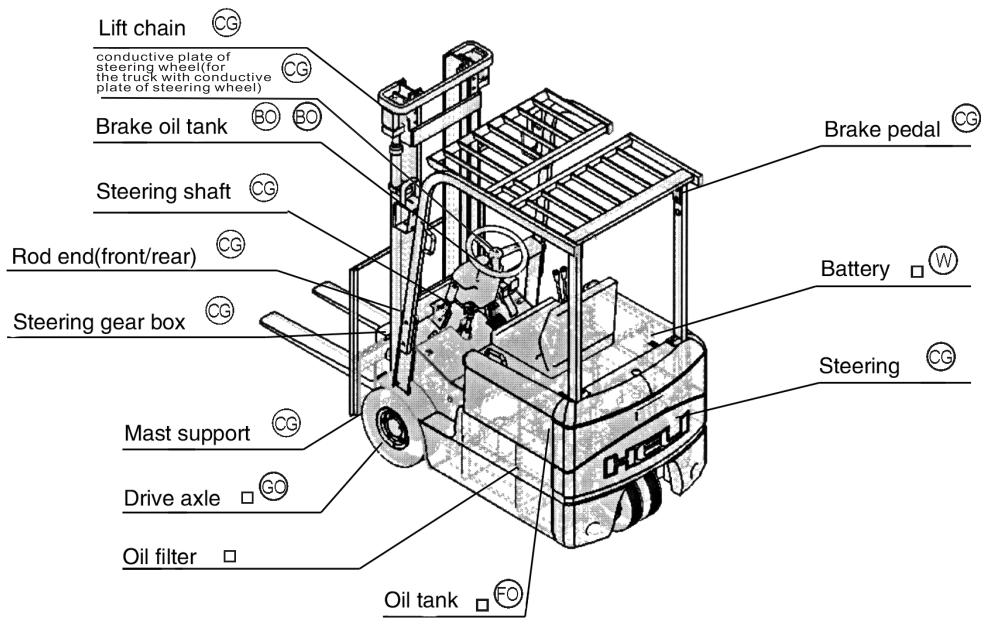



(2)Recommended oil

Manufacture use	Shell	ESSO	Mobile	Brand for home users
Hydraulic system	Normal temperature : Shell Tellus S2 V 46 Low temperature : Shell Donax TC 10W		Normal temperature : Mobil DTE 10 Excel 25 Low temperature : Mobil DTE Excel 46	HLW-40 (Dedicated for HELI)
Gear oil	Spirax EP90	ESSO Gear Oil GP-90	Mobilube BX-80	85W/90
Grease	Alvania Grease2 Retinax A			3# lithium base grease(drop point 170)
Brake fluid	Shell Brake Fluid H.D.	ESSO Fluid H. Brake Fluid H.D.400	Mobil Brake Fluid (SAI70RI)	4604 Compound brake fluid

Note: the lubricating grease for the conductive plate for steering wheel is NYOGEL 782G.

## 2. Replacing Parts Guidance

(1)Replacing fuses

### CAUTION

**Be sure to disconnect the battery plug.**

	Replacing procedure
Fuses	Loosen the mounting nuts and remove the fuses.
Cartridge fuse	Loosen a cap and remove the fuse.
Insufficient tightening cause a poor contacting and it will lead to making failures. Tighten the nuts securely.	

### CAUTION

**Be sure to use the prescribed fuses.**

- ①Fuse 400A(for travel)
- ②Fuse 400A(for hydraulic)
- ③Fuse 50A(for power steering)
- ④Cartridge fuse 10-15A(for control circuit)

**HELI**  
LIFTING THE FUTURE

ADD:NO.668 Fangxing Street,Economical  
Development Zone,Hefei ,P.R.China  
TEL:(86 551)63689000  
FAX:(86 551)63689666  
400 SERVICE: 4001-600761  
WEBSITE:<http://www.helichina.com>

**S41-17-2019**

**FREE SERVICE HOTLINE**

**4001 600 761**

Fokeli Print

Anhui Leading Forklift Parts Co., Ltd.  
[www.leadingforkliftparts.com](http://www.leadingforkliftparts.com)  
[www.youtube.com/@leadingforkliftparts](http://www.youtube.com/@leadingforkliftparts)